



FTIR-8400s

FOURIER TRANSFORM INFRARED SPECTROMETER SHIMADZU

Stablish Year- 2009

In Physics Lab

Pure & Applied Physics

GGV Koni Bilaspur (c.g.)



FTIR Analysis

FTIR-8400S

Shimadzu
Fourier Transform
Infrared Spectrophotometer





Discover the Advantages of the FTIR-8400S

FTIR-8400S

Shimadzu Fourier Transform Infrared Spectrophotometer

Discover the Advantages of the FTIR-8400S

Shimadzu was the first company to offer dynamic alignment as a standard feature in an affordable FTIR spectrometer. With state-of-the-art technology, the Shimadzu dynamic alignment system continuously maintains optimal alignment during data acquisition, ensuring consistently reproducible spectra without the need for tedious mechanical adjustments.

FTIR-8400S is combined with the IRsolution - a 32 bit high performance FTIR software - to analyze your samples easily and securely.

The Dynamic Alignment Advantage

Optimal interferometer alignment is maintained automatically for continuous optimization and exceptional reproducibility.

The Signal-to-Noise Advantage

Peak-to-Peak S/N ratio is 20,000:1 or better, guaranteed!

The Simplicity Advantage

New FTIR operators will love the quick-start function that prompts the user through every action from setting scan parameters and acquiring the spectrum, to detecting peaks and printing.

The IRsolution Advantage

Powerful IRsolution software offers a myriad of standard data processing functions. The management of User group, protection by user name/password, Operrecording, and Electric Signature supports the FDA 21 CFR Part 11. ^{note)}

The Validation Advantage

The software validates instrument performance to ensure compliance based on Japanese/European Pharmacopoeia and ASTM. The instrument and data reliability are ensured by GLP/GMP and FDA 21 CFR Part 11 compliance.

note) IRsolution Agent software is needed to fully comply to FDA 21 CFR Part 11 regulation.

Contents

P 04 - Hardware Features	P 10 - Software	P 13 - Hardware Reliability
P 06 - Versatility	P 12 - Validation Reliability	P 14 - Optional Software

FTIR-8400S

[Maximum resolution of 0.85cm^{-1} . Excellent signal-to-noise of 20,000:1 or better.]

With a maximum resolution of 0.85cm^{-1} , the FTIR-8400S achieves the best signal-to-noise ratio in its price-class by 20,000:1 or better (peak-to-peak, 4cm^{-1} resolution, averaged over 1 minute). Designed with the user in mind, this instrument can be operated using an ordinary desktop or a laptop PC.

- 0.85cm^{-1} maximum resolution
- 20,000:1 or better peak-to-peak S/N ratio
- Dynamic alignment ensures optimum performance
- On-screen instructions for easy operation
- Laptop PC control is available.



Dynamic alignment ensures reproducibility by maintaining optimum alignment

Highly precise control of the moving mirror is required to stabilize the interferogram of the FTIR instrument. The FTIR-8400S includes the patented FJS system - very smooth and precise moving mirror unit - and the Dynamic Alignment system to optimize and stabilize the interferometer unit. FTIR-8400S requires only a short stabilization time and is very secure.

Dynamic Alignment (Patented)

This System monitors the interferometer condition of He-Ne laser and compares it with that of optimized conditions.

Any detected discrepancies by DSP system are corrected by automatic alignment of the piezo actuators at the fixed mirror.

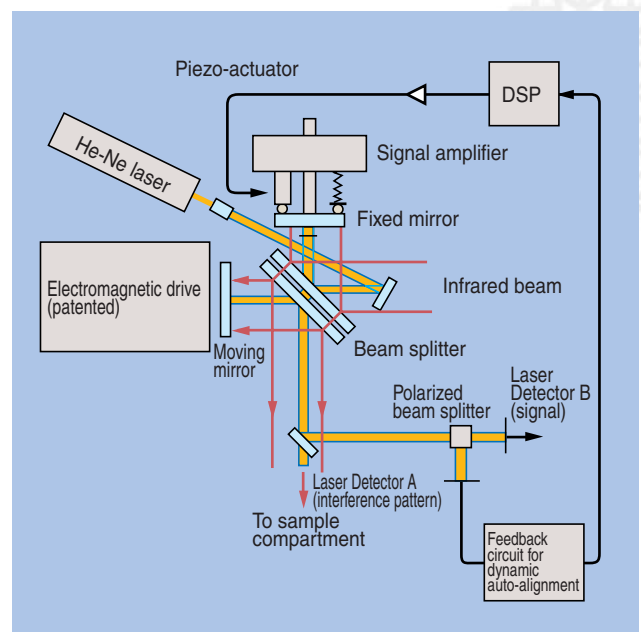

Versatility 1

[Interface with a wide variety of sampling accessories. Microscopy and automation options are available.]

Match the versatile FTIR-8400S with automation and microscopy options, as well as a wide variety of Shimadzu and other commercially available accessories, to easily accommodate a myriad of sample types.

FTIR Microscopy System featuring the Shimadzu AIM-8800

Perform high-precision analysis of micro-samples as small as $10\mu\text{m}$ quickly and easily with this fully automated FTIR microscope system, equipped with a high sensitivity MCT detector. The standard features include auto aperture, auto focusing, auto X-Y-Z stage movement and auto centering, as well as the transmittance and reflectance modes, and the on-board video-camera. Meet all your sampling requirements with such convenient options as grazing angle objectives, various ATR objectives and mapping software.



Universal sampling with a diamond ATR



Left Side : System I (High Pressure Device type)
Right Side : System H (ViewIR type)

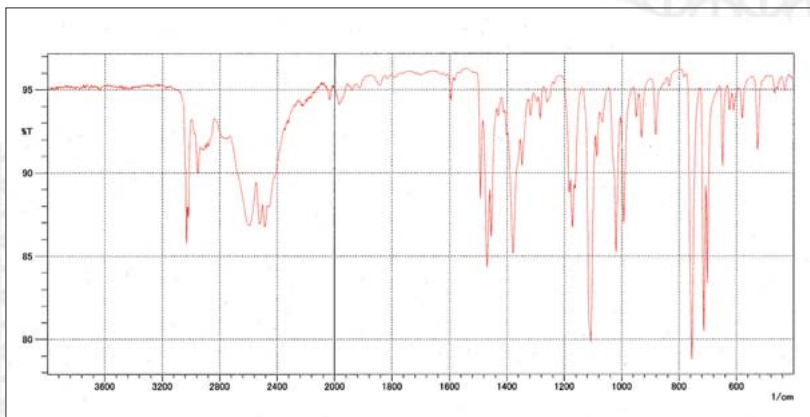

Infrared spectrum of diphenhydramin hydrochloride (powder sample) measured with DuraSamplIR II A (ATR-corrected spectrum)

The DuraSamplIR II A has two types of diamond prism, a diamond prism supported by a ZnSe lens and a diamond prism supported by a KRS-5 lens. The ZnSe type can measure up to around 600cm^{-1} . On the other hand, the KRS-5 type can measure up to around 400cm^{-1} . The infrared spectrum of diphenhydramin hydrochloride measured with the diamond prism supported by a KRS-5 lens is shown above. The KRS-5 type can give the infrared spectrum without noise up to 400cm^{-1} . Plastics, rubbers, films and liquid samples can be measured with the DuraSamplIR II A.

Versatility 2

For Liquid samples

For measuring liquid samples, demountable or sealed liquid cells may be used. Additionally, the ATR (Attenuated Total Reflectance) accessories are also convenient.

To measure liquids with ATR, sample preparation is as simple as dispensing the liquid onto the prism of the accessory. The ATR correction program in the IRsolution software converts the measured ATR spectrum into a normal transmittance measurement by correcting for depth penetration differences.



ATR-8200HA (P/N 208-97240-91)

A liquid sample trough plate and a solids flat plate prisms are available to conveniently accommodate a range of liquid, solid and film samples. The ZnSe prism is standard in most accessories. A Ge prism is available for high refractive index samples such as black rubber. Both the ZnSe prism and the Ge prism are water resistant, so even aqueous solutions can be easily and conveniently measured.



MIRacle A (ZnSe : P/N 208-97247-95) Ge : P/N 208-97247-96

Single bounce ATR with a 2mm diameter prism. This accessory is suitable for liquid, solids, powders, films, and a variety of other sample types. The ZnSe prism is standard. A Ge prism is available for high refractive index samples.

For powder samples

For measuring powder samples, conventional KBr pellet methods may be used. The Diffuse reflectance method is also convenient and requires less sample preparation. In the Diffuse reflectance method, the sample is mixed with KBr powder and then measured, there is no need for making a pellet. Single Bounce ATR accessories may also be used for powder samples in some cases.



DRS-8000A (P/N 206-62301-91)

Sample is mixed with KBr powder, placed in a sample cup and measured. With the Kubelka-Munk conversion in the IRsolution software, the diffuse reflected spectra can be converted into transmission spectra for comparison purposes.

For gases

Various gas cells are available for gas sample measurement. The path length is selected according to concentration of the gas. Various path length cells are available ranging from 5cm to 20m.

5cm gas cell P/N202-32006-30(KRS-5 window)

10cm gas cell P/N202-32007-30(KRS-5 window)

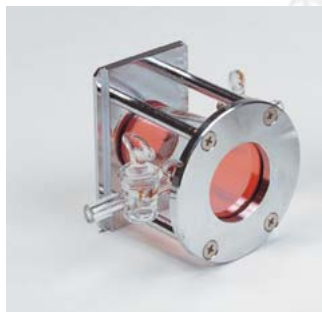

5cm gas cell



10m gas cell

For solid samples, films, cast resins

The transmission method is effective for film samples up to 100µm thick. For films thicker than 100µm, multi layer film and cast resins, ATR (Attenuated Total Reflectance) is recommended. Samples are clamped to the prism to ensure contact. With the ATR method, a spectrum is taken through a depth of a few µm within the sample. For samples with high refractive indices, the Ge prism is suitable. For hard samples, the diamond prism is preferred. With the ATR correction available within the IRsolution software, ATR spectra is converted into a normal transmittance spectra. Another method for these sample types, involves scratching the surface of the sample and measuring with a diffuse reflectance accessory.



ATR-8000A (P/N 206-62303-91)

This accessory can measure film samples clamped firmly on one or both sides of the prism. A large contact area results in good sensitivity. The KRS-5 prism is standard, a Ge prism is also available for samples with a high refractive index. The incident angle on the sample is switchable between 30/45/60°, allowing for accumulation of spectra at different depths.



ATR-8200HA (P/N 208-97240-91)

A liquid sample trough and a solids flat plate prism are available to conveniently accommodate a range of liquid, solid and film samples. The ZnSe prism is standard in most accessories. A Ge prism is available for high refractive index samples. The measuring light is reflected through the prism 10 times. The sample is clamped firmly to the prism to ensure contact with an attached clamp and easily adjustable clamp pressure.



MIRacle A (ZnSe : P/N 208-97247-95) Ge : P/N 208-97247-96)

Single bounce ATR with a 2mm diameter prism. This accessory is suitable for liquid, solids, powders, films, and a variety of other sample types. The ZnSe prism is standard. A Ge prism is available for high refractive index samples. The sample can be easily clamped to prism with the attached clamp with adjustable pressure. For hard samples, the Diamond MIRacle with diamond prism is available.

DuraSampIR II A System I DuraSampIR II A System I DuraSampIR II A System H

(With Pressure Sensor)

(ZnSe support:P/N 208-92143-11)
(KRS-5 support:P/N 208-92143-12)

(ZnSe support:P/N 208-92144-11)
(KRS-5 support:P/N 208-92144-12)

(ZnSe support:P/N 208-92145-11)
(KRS-5 support:P/N 208-92145-12)

Single Bounce ATR with a 2mm diameter diamond prism. This accessory is good for measuring hard samples that may damage other prism types. It is also suitable for liquid, solids, powders, films, and a variety of other sample types. The System I (High Pressure Device Type) allows the sample to contact the prism easily with the attached clamp and adjustable pressure. The System H (ViewIR Type) allows the sample to be visually observed while clamping.

SiC Sampler (P/N 200-66750)

This sample preparation accessory has SiC emery paper that is used to scratch the sample of interest. The powder of the sample on the emery paper is directly analyzed with a Diffuse Reflectance Accessory.



Versatility 2

For coating films on metals or resins

For coatings, Reflectance is the measurement method is a choice. Selection of Specular Reflection or Reflection absorption method is dependent on the thickness of the coating sample.



SRM-8000A (P/N 206-62304-91)

Specular Reflectance accessory with 10° reflection. Samples are placed on the top of the accessory with the measurement side down. Analysis of μm thick thin films is possible. The specular reflectance spectra can convert into a transmittance spectra with Kramers-Kronig conversion in the IRsolution software.



RAS-8000A (P/N 206-62302-91)

Reflection absorption spectroscopy method accessory with 70° or 75° reflection angle. Analysis of nm thick thin films is possible. The optional GPR-8000 polarizer allows for higher sensitivity measurement. When a polarized light beam is incident on a metal substrate, the phase of the light is changed. In vertical polarization, the vectors of the polarized light are opposite to each other, and hence no stationary waves are produced. In parallel polarization, the the vectors of the polarized light meet at the point to produce stationary waves, which enhances the sensitivity of the measurement.

Accessory for automated analysis

Various automation accessories, are available to provide efficient analysis of large numbers of samples.



ASC-8000T (P/N 206-63900)

ASC-8000T is an auto sample changer for performing transmission measurements on up to 18 samples. The holder is designed for 13mm diameter KBr pellets and optional film-holder or cell plates for Nujol mulls are also available. The ASC-8000T can be easily controlled by the IRsolution software.

Applications

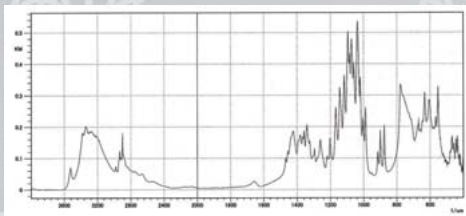

Infrared spectrum of lactose

Infrared spectrum of lactose measured with the DRS-8010ASC automatic diffuse reflectance accessory (Kubelka-Munk concerted spectrum)



DRS-8010ASC (P/N 206-62308)

DRS-8010ASC are automatic diffuse reflectance accessories. The DRS-8010ASC accepts up to 24 samples. The DRS-8010ASC can be easily controlled by IRsolution software.

Versatility 3

Space Efficient Laptop PC Control

A unique laptop PC rack option ^(note1) reduces the system footprint to just 630mm (W) by 592mm (D), and the height to only 530mm. Process your data anywhere with this portable PC option.

(note1) Rack accommodates 13.3 inch laptop PC.

(note2) Microscope-equipped systems require desktop PC.

(note3) Special SCSI interface for laptop PCs is required.



Easy Operation

The simplicity of the software makes it perfect for routine work within QA/QC departments or educational institutions, the main procedure is to operate some limit number of functions. In either case, procedures can be simplified by standard Easy-Scan program, all procedures including the setting of measurement parameters, analysis of the sample, data processing, saving, and printing the results are performed with one click operation.

The IRsolution software is equipped with an Easy-Scan program. This macro program takes the user step by step through the entire analysis from spectrum measurement, peak detection, printout and saving of the result data. On screen instructions guide the operator ever step of the way. This feature allows for a decrease in the learning curve for operating the IRsolution and the FTIR-8400S.

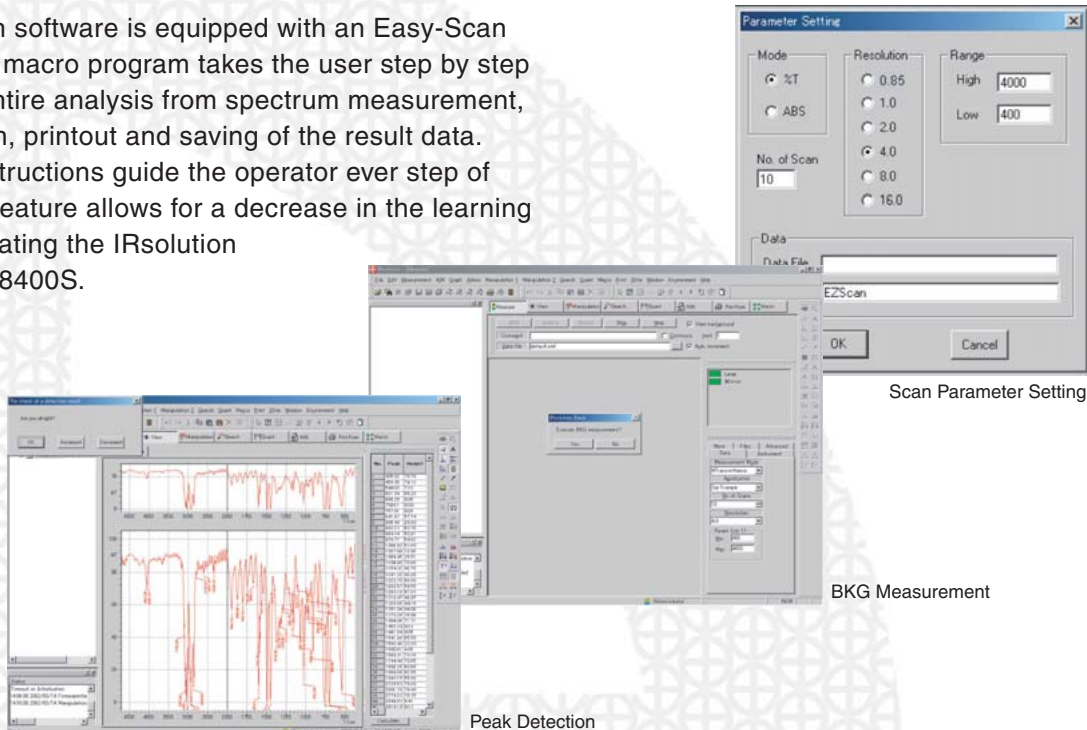

Scan Parameter Setting

BKG Measurement

Peak Detection

IRsolution

IRsolution software provides windows based 32bit software control for the FTIR-8400S. With IRsolution, operations for FTIR analysis can be performed easily and quickly using dedicated analysis screens

- Spectrum measurement
- Data display and comparison to other spectra
- Data processing, quantitation and spectral searching
- Report Generation

As the operation progresses, the IRsolution software automatically advances into the optimum mode. Optional software such as PLS quantitation modules are available for increased versatility.

You can quickly access the many useful functions of IRsolution by customizing the User Interface of software.

Measurement and Status Monitor

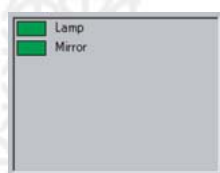
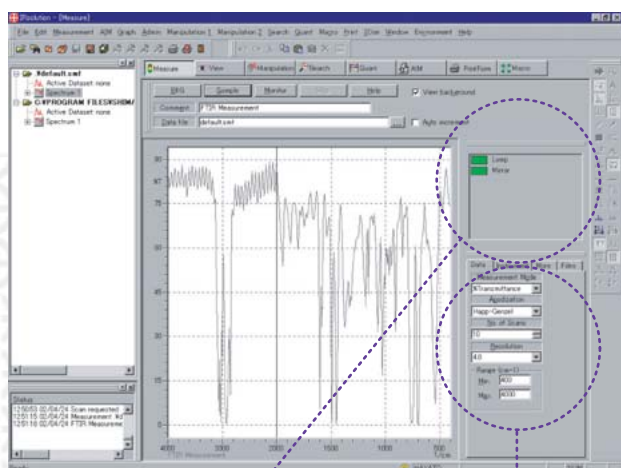

Status Monitor

In the measurement menu of IRsolution, all measurement start buttons and dialogs to set the analysis parameters are integrated for easy operation. All measurement parameters are arranged into four dialog screens that are easily viewed.

One click operation will start the analysis. During measurement, a real time spectrum is displayed on screen.

The hardware settings are displayed on the status monitor screen.

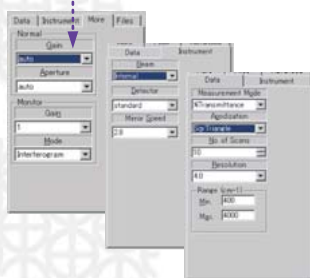

View Mode

After the data is acquired, you can use the View Mode to zoom in on certain areas or compare with other spectra.

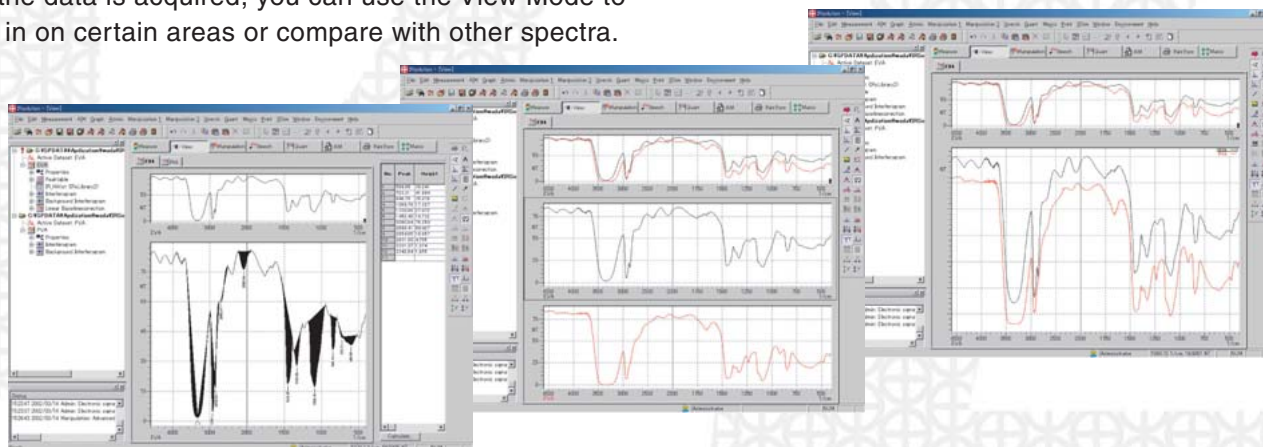

Data Manipulation, Quantitation and Spectrum Search

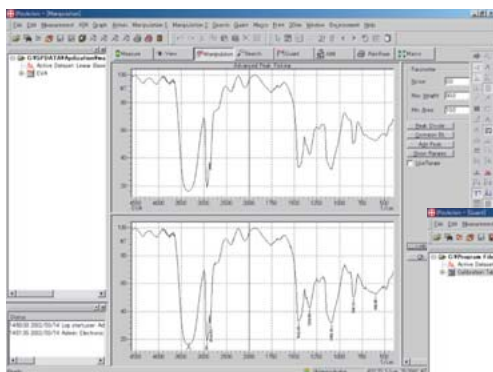

Peak Picking

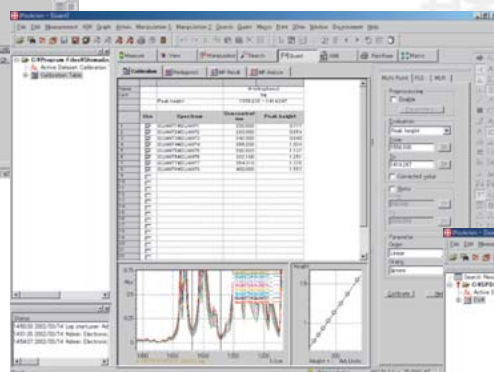

Quantitation

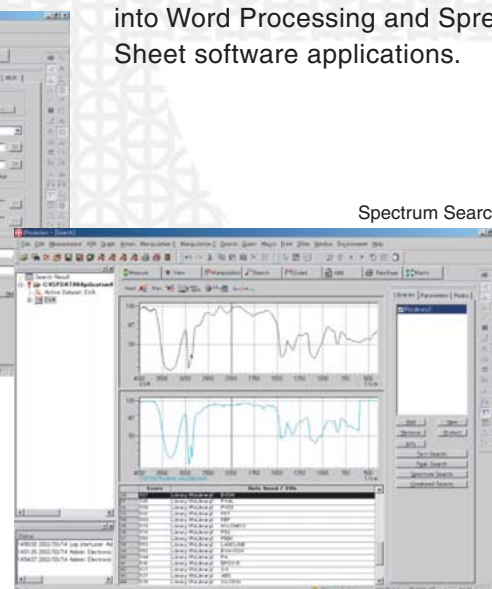

Spectrum Search

Quantitation

In addition to multi-point calibration curve methods, the IRresolution software offers MLR (Multi Linear Regression) and optional PLS (Partial Least Squares) analysis that is useful for NIR measurements.

Spectrum Search

The IRresolution software allows the creation of user libraries from acquired spectra, and spectral searching of user and commercial libraries.

Report Generator

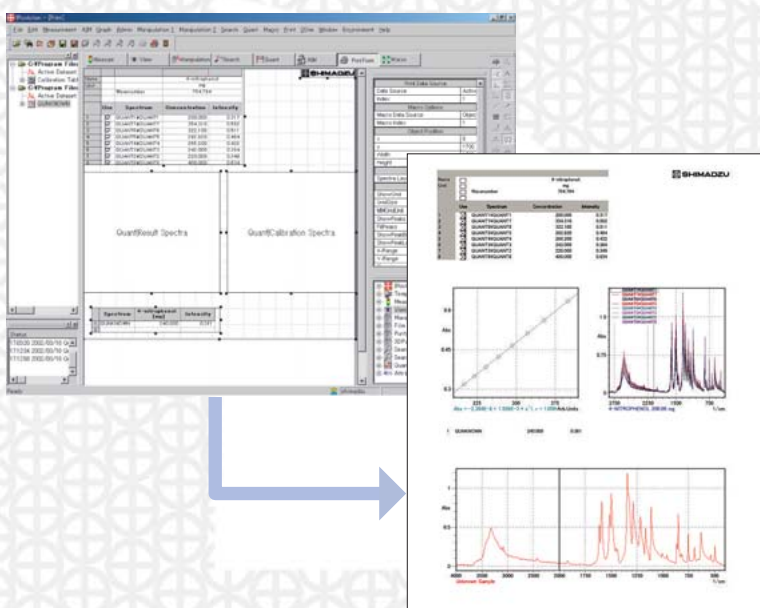

Data is not useful unless you can get the results in the desired format.

The IRresolution software includes a powerful report generator with customized layout features. With the Report Generator, you can create reusable print templates using any data including the spectrum, calibration curve, quantitation results and peak pick tables. You can set the thickness and color of the graph lines as well as the font size. Annotations may be attached on the graph to comment on the results.

The print layout can be saved as a template file for later use, ensuring accurate repeat reporting.

Reliability 2

The Interferometer is one of the most important parts of the FTIR. For accurate data collection, the interferometer must scan with high precision. The FTIR-8400S includes the Patented FJS system which scans the moving mirror with a smooth and stable mechanism. The optimization and stabilization of the FTIR-8400S interferometer by Dynamic Alignment system ensures consistent and repeatable results. Since the beam splitter within the interferometer is susceptible to moisture, the optical system of the FTIR-8400S is sealed and desiccated.

Protection of the Interferometer and Atmosphere Correction

The Interferometer is one of the most important parts of the FTIR.

The FTIR-8400S has 3 features to stabilize the interferometer and to protect the beam splitter.

1. Sealed optical system to create closed environment
2. Anti Humidity Beam Splitter coating to provide extra protection
3. Desiccated interferometer to remove moisture by Desiccants

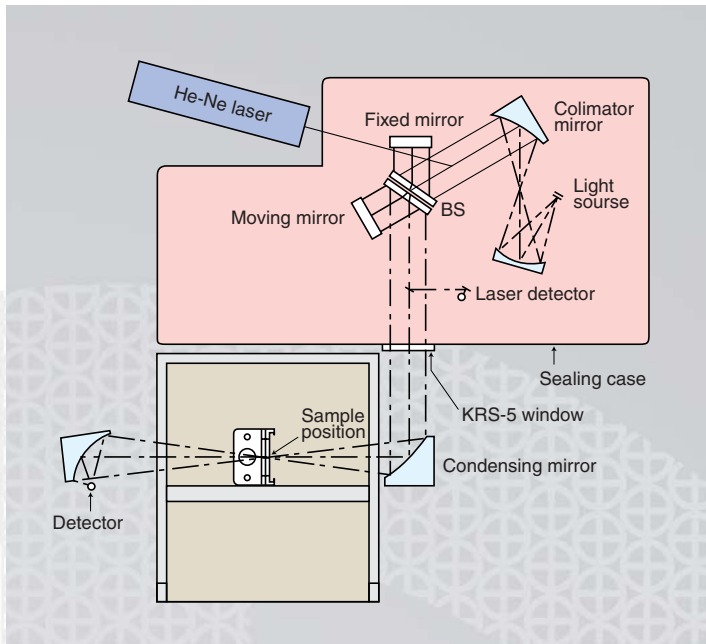

The Atmosphere Correction Function easily compensates for the influences of water vapor and carbon dioxide on your data. You can easily get beautiful spectra with the FTIR-8400S even if the sample has peaks which are overlap with water vapor around $2100-1300\text{cm}^{-1}$ or $4000-3100\text{cm}^{-1}$.

Elimination of influences of CO₂ and H₂O by Atmosphere Correction

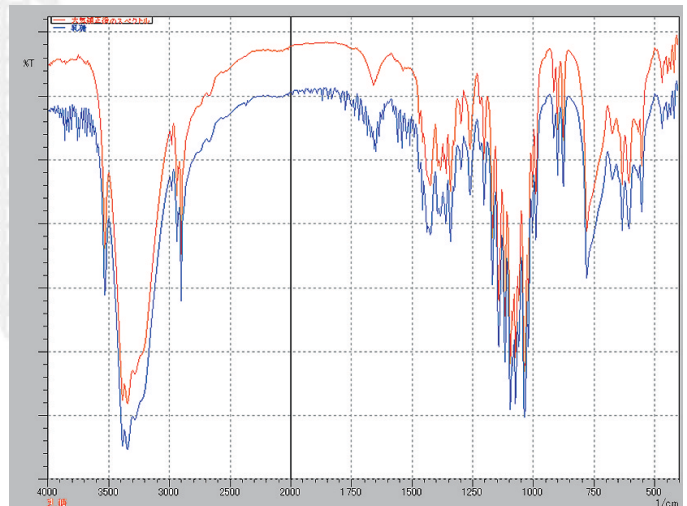

Blue : Spectrum Before Atmosphere Correction Red : Spectrum After Atmosphere Correction

Optional Software

Wide varieties of optional software to enhance IRsolution capabilities

Powerful 32-bit Windows based software - IRsolution - has various optional software modules to enhance its performance:

- IRsolution Agent
- Mapping software - AIM-MAP (for the AIM-8800 Microscope)
- PLS quantitation software
- Curvefitting (Peak split) software
- PharmaReport Program ^{note}
- Macro Platform

IRsolution includes a wide selection of data manipulation operations which include: spectral subtraction and Kubelka-Munk conversion; Variety of Quantitation operations - Multi-point Method and Multiple Linear Regression (MLR) method; as well as Spectral search functions. The optional software for IRsolution expands the application capabilities of IRPrestige-21. ^{note} In order to use PharmaReport Program, the separately available Macro Platform is required.

IRsolution Agent (P/N 206-21600-92)

IRsolution Agent software is an Add-On software module for IRsolution to meet FDA 21 CFR Part 11 regulations and/or to manage obtained data. IRsolution Agent software consists of a database function and a data registration function from IRsolution to IRsolution Agent, as well as electronic signature capabilities.

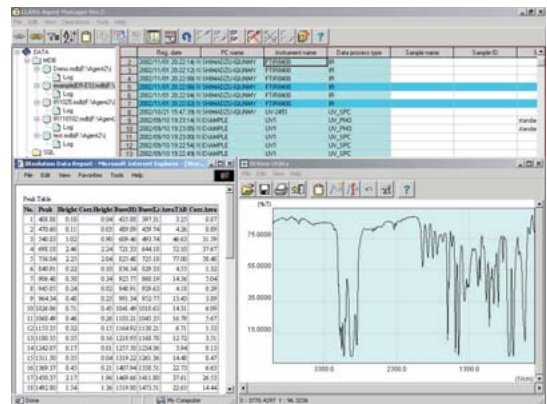

CLASS-Agent screen and data registered in CLASS-Agent database

Mapping Program AIM-MAP (P/N 206-72332-91)

Mapping Software - AIM-MAP - captures visual images from the AIM-8800 microscope and creates a large composite visual image of your sample. Mapping conditions such as Mapping area, Scan intervals, Background position and etc. are set up on the composite image. You can operate the AIM-8800 microscope and AIM-MAP through simple point and click operations. AIM-MAP has 3 types of mapping modes - Area mapping, Line mapping and Random mapping. Not only can traditional transmittance/reflectance measurements be done, but also micro-ATR mapping with an optional ATR objective are available. IRsolution mapping has various data manipulation functions such as extracting a spectrum from mapped data or reprocessing functional-group mapping. The mapped data can be shown as 3D bird's-eye view, counter plot or spectral overlay mode.

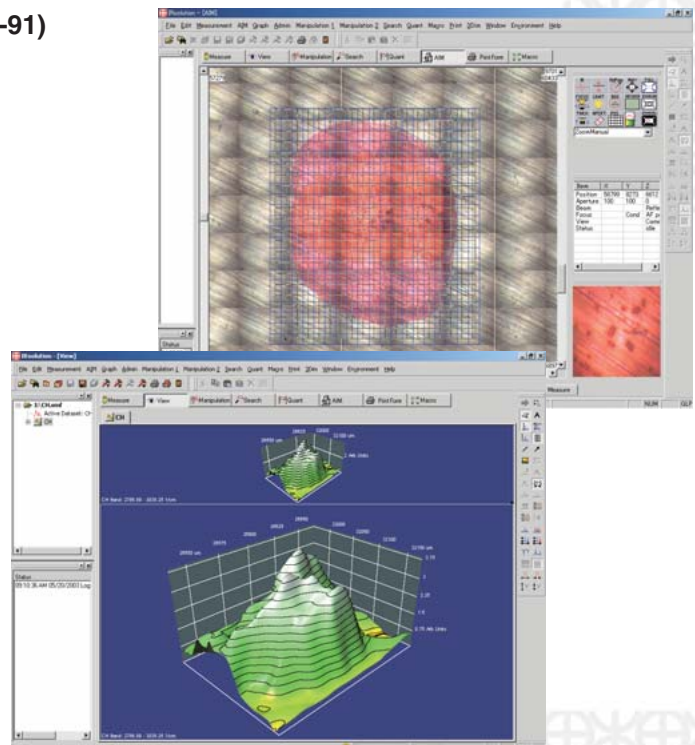

Area mapping data
Mapped data of flux on a circuit board

PLS Quantitation Software (P/N 206-72331-91)

PLS (Partial Least Squares) quantitation is a widely used Chemometrics method like Multiple Linear Regression (MLR) method for quantitation of multicomponents.

IRsolution has PLS I and PLS II method for PLS quantitation. IRsolution analyzes PLS calibration curves by calculating "Influence", "Residuals", "Scores", "Loadings", "Press Values", etc.

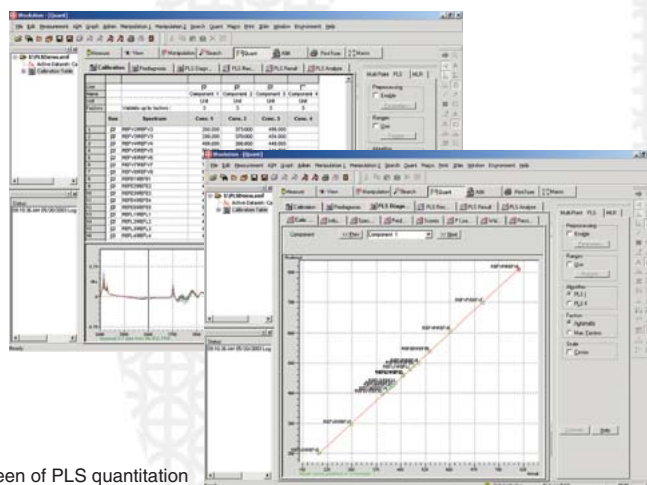

Screen of PLS quantitation

Curve fitting (Peak split) Software (P/N 206-72333-91)

Usually, an IR band can consist of several overlapping peaks. Curve fitting (Peak split) software separates IR bands to individual component peaks. This software is good for many applications such as analysis of peak with hydrogen bond influences, and analysis of hidden peaks overlapped with other peaks. Curve fitting (Peak split) software separates the band with suitable curves from 6 types of curve such as Gaussian, Lorentian, Gaussian+Lorentian. Component peaks and a synthesized peak are displayed to evaluate the separation.

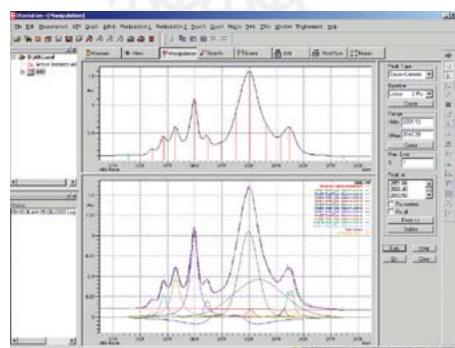

Curve fitting (Peak split) result of peak (3150-2750cm⁻¹) of ABS resin spectrum.
Top : Target peak and specified peaks
Bottom : Component peaks and a synthesized peak

PharmaReport Program note (P/N 206-72365-91)

This optional program compares the measured spectra of test samples with the spectra of reference samples previously measured and registered to generate Pass/Fail reports based on the identification test in the pharmacopoeias.

The program conducts the following calculations and comparisons:

- Calculates the discrepancy in the peak wavenumbers of the sample being checked and the reference previously registered.
- Calculates the peak intensity ratio at several designated evaluation peaks for comparison between the sample and reference.
- The result is evaluated as "Pass" if both the wavenumber discrepancy and peak intensity ratio fall within the permissible range.

In addition to the functions above, it is also possible to detect and print the previously designated peaks only, and to print out the spectra of the measured sample and the reference side by side.

note) In order to use this program, the separately available Macro Platform (P/N:206-72330-91) is required.

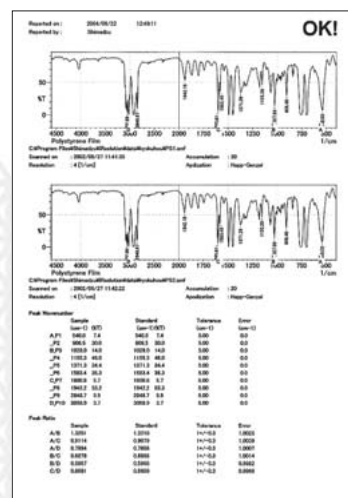

Macro Platform (P/N 206-72330-91)

Macro Platform is a module to run Macro programs provided by Shimadzu on IRsolution software. Please contact your Shimadzu representatives when you need an automatic measurement system with an automatic sample changer or to do routine operation with repeated specified operations.

Specifications

Interferometer	Michelson type with 30° incident angle, dynamic alignment, sealed and desiccated
Optical system	Single beam optics
Beam splitter	Germanium-coated KBr plate
Light source	High brightness ceramic
Detector	Temperature controlled high sensitivity detector (DLATGS detector)
S/N ratio	Greater than 20,000:1 (KRS-5 window, 4cm ⁻¹ , 1 minute, 2200cm ⁻¹ , P-P)
Wavenumber range	7,800cm ⁻¹ - 350cm ⁻¹
Resolution	0.85, 1, 2, 4, 8, 16cm ⁻¹
Mirror speed	3 steps; 2.8, 5, 9mm/sec
Data sampling	He-Ne laser
Sample compartment	W200mm x D230mm x H170mm
Data processing functions	Arithmetic operation between spectrum and constant, Arithmetic operation among spectra, Spectral subtraction, Peak detection, Smoothing, Derivative, Baseline correction, Data correction, Normalization, Kubelka-Munk conversion, Kramers-Kronig analysis, ATR correction
Optional programs	IRsolution Agent, PLS quantitation, Curve fitting, Mapping, Macro platform, PharmaReport Program
Validation programs	Compliance to Japanese/European Pharmacopoeia and ASTM
GLP/GMP	Operation log recording, Software protection by user name/password, Management of user level
FDA 21 CFR Part 11 ^(note1)	Electronic signature, Data manipulation history recording, Saving of measured interferogram/background spectrum/manipulated spectra
Ambient conditions	15 - 30°C Less than 70%
Power requirement	AC100/120/220/230/240V 50/60Hz 160VA ^(note2)

(note1) IRsolution Agent software is needed to fully comply to FDA 21 CFR part 11.

(note2) PC requires additional power.

PC Specifications

Type	Desktop (SCSI interface for desktop PC is required.) Notebook (SCSI interface for notebook PC is required.)
OS	Microsoft Windows 2000 ^(note3)
CPU	Celeron 766MHz or Duron 850MHz or Pentium III 850MHz and later ^(note4)
Video	1024 x 768 pixels/256 color or better
RAM	128MB and more
HDD	30MB and more for free space

(note3) Windows is a trademark of Microsoft Corporation.

(note4) Celeron and Pentium are trademarks of Intel Corporation, Duron is trademark of Advanced Micro Devices, Inc.



JQA-0376

Founded in 1875, Shimadzu Corporation, a leader in the development of advanced technologies, has a distinguished history of innovation built on the foundation of contributing to society through science and technology. We maintain a global network of sales, service, technical support and applications centers on six continents, and have established long-term relationships with a host of highly trained distributors located in over 100 countries. For information about Shimadzu, and to contact your local office, please visit our Web site at www.shimadzu.com



SHIMADZU CORPORATION. International Marketing Division
3. Kanda-Nishikicho 1-chome, Chiyoda-ku, Tokyo 101-8448, Japan
Phone: 81(3)3219-5641 Fax: 81(3)3219-5710
URL <http://www.shimadzu.com>

Dimensions

With desktop PC (Unit : mm)

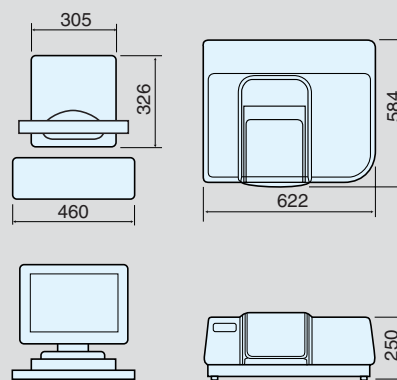

With laptop PC using rack (Unit : mm)

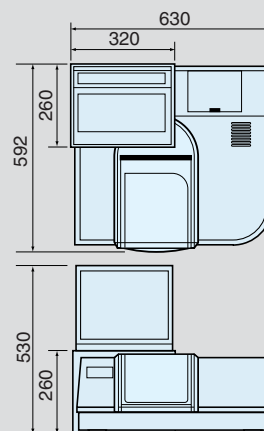

(note5) Dimensions for PC and Printer depend on models.