

शुद्ध एवं अनुप्रयुक्त भौतिकी विभाग  
**Department of Pure and Applied Physics**  
गुरु घासीदास विश्वविद्यालय, बिलासपुर छ.ग.  
**Guru Ghasidas University, Bilaspur (C.G.)**



**DEPARTMENT OF PURE AND APPLIED PHYSICS M.Sc. (Physics) Course Syllabus  
under CBCS/LOCF Academic year 2021-22**

**Semester - 1**

**Core -3: Electronics and Experimental Methods Lab**

**Course Code: PPPALT3**

## **Electronics and Experimental Methods Lab**

- **Study the operational Amplifier as inverting and non-inverting amplifier**
- **Study the operational Amplifier as a summing amplifier (Voltage adder and voltage subtraction).**
- **Study the operational Amplifier as a differentiator and integrator.**
- **A study of V-I characteristics of light emitting diode (LED).**
- **Study of Solar Cell characteristics**
- **Photoconductivity (Photocurrent as a function of irradiance at constant voltage)**
- **Design of regulated Power Supply**
- **Verification of De Morgan's Theorem**
- **To design a digital to analog converter (DAC) of given specifications**

## Experiment -01

**Objective** -Study of operational amplifier (741) type as inverting and non-inverting amplifier.

**Apparatus Required** – Bread board, 741 IC,  $\pm 12V$  power supply, resistors, CRO with probe and connection wires.

**Electronics and Experimental Methods Lab** - The op-amp is a versatile device that can be used to amplify dc as well as ac input signals and was originally designed for computing such mathematical function as addition , subtraction , multiplication , differentiation and integration. With the addition of suitable external feedback components the modern day op amp can be used for a variety of applications such as ac and de signal amplification, active filters, oscillators, comparators, regulators and others.

### **An ideal op-amp exhibit the following characteristics-**

- I. Infinite voltage gain (A).
- II. Infinite input resistance  $R_i$ , so that almost any signal source can drive it and there is no loading of the preceding stage.
- III. Zero output resistance  $R_0$  so that output can drive an infinite number of other devices.
- IV. Zero output voltage when output voltage is zero.
- V. Infinite bandwidth so that any frequency signal can be amplitude without attenuation.
- VI. Infinite common mode rejection ratio so that output common mode noise voltage is zero.

Infinite slew rate so that output voltage changes occur simultaneously input voltage changes.

The gain of the inverting amplifier is simply given by

$$A = -R_f/R_1$$

So the output voltage

$$V_o = -V_{in} R_f/R_1$$

And the gain of the non - inverting amplifier is given by

$$A = R_1+R_f/R_1$$

Hence the output voltage

$$V_o = V_{in} (R_1+R_f/R_1)$$

**Circuit Diagram:-**

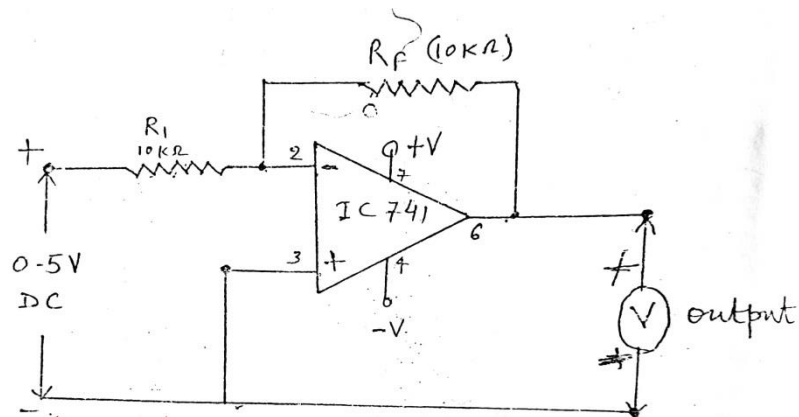

fig ① Inverting Amplifier

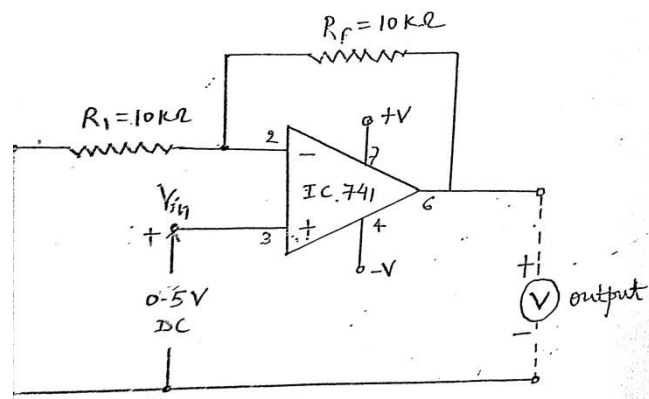

fig ② - Non - inverting amplifier

Basic circuit diagram for inverting and non-inv amplifiers are schematically shown in fig. (1) and fig. (2) respectively.

**Observation Table-**

Table -1. For Inverting amplifier

S. No.	V <sub>in</sub> (volt)	V <sub>out</sub> (Theoretical) (volt)	V <sub>out</sub> (Practical) (volt)
1			
2			
3			
4			
5			

Table -1. For Non-Inverting amplifier

S. No.	V <sub>in</sub> (volt)	V <sub>out</sub> (Theoretical) (volt)	V <sub>out</sub> (Practical) (volt)
1			
2			
3			
4			
5			

**Calculations:-**

The output voltage of the inverting amplifier  $V_{out} = - V_{in}(R_f/R_1)$   
 $= \dots\dots\dots$ volt

The output voltage of the Non-inverting amplifier

$$V_{out} = - V_{in} [1+ (R_f/R_1)]$$

= ....volt

**Results:** It is clear from the table 1 and table-2 that the theoretical and practical values of output voltages are approximately equal. Hence the op-am works as an inverting and non-inverting amplifier.

**Precautions:-**

1. All connections should be tight.
2. Readings should be taken very carefully.

## Experiment – 02

**Objective** -Study of Operational Amplifier as adder and subtractor.

**Apparatus Required** – Bread Board, 741 IC,  $\pm 12V$  power supply, Resistors and connection wires.

**Theory and formula used-** The op-amp is a versatile device that can be used to amplify dc as well as ac input signals and was originally designed for computing such mathematical function as addition , subtraction , multiplication , differentiation and integration. With the addition of suitable external feedback components the modern day op amp can be used for a variety of applications such as ac and de signal amplification, active filters, oscillators, comparators, regulators and others.

wheneve we need to combine two or more analog signals into a single output, the summing amplifier or adder is a natural choice.

The summing amplifier or adder combines all the amplified input signals into a single output, given by

$$V_{out} = -(R_f/R_1)V_1 + R_f/R_2V_2$$

If  $R_f = R_1 = R_2 = 1 \text{ k}\Omega$

Then  $V_{out} = - (V_1 + V_2)$

This means that the output voltage is equal to the negative sum of all the inputs times the gain of the circuit ( $R_f/R_1$ )

If  $R_f = R_1 = R_2$ , then the output voltage is equal to the negative sum of all input voltages

i.e.  $V_{out} = - (V_1 + V_2)$

A subtractor is a basic differential amplifier. The output voltage of the differential amplifier is

$$V_{out} = -(R_f/R_1) (V_1 - V_2)$$

If  $R_f = R_1$

$$V_{out} = -(V_1 - V_2)$$

Or  $V_{out} = V_2 - V_1$

**Circuit Diagram:**

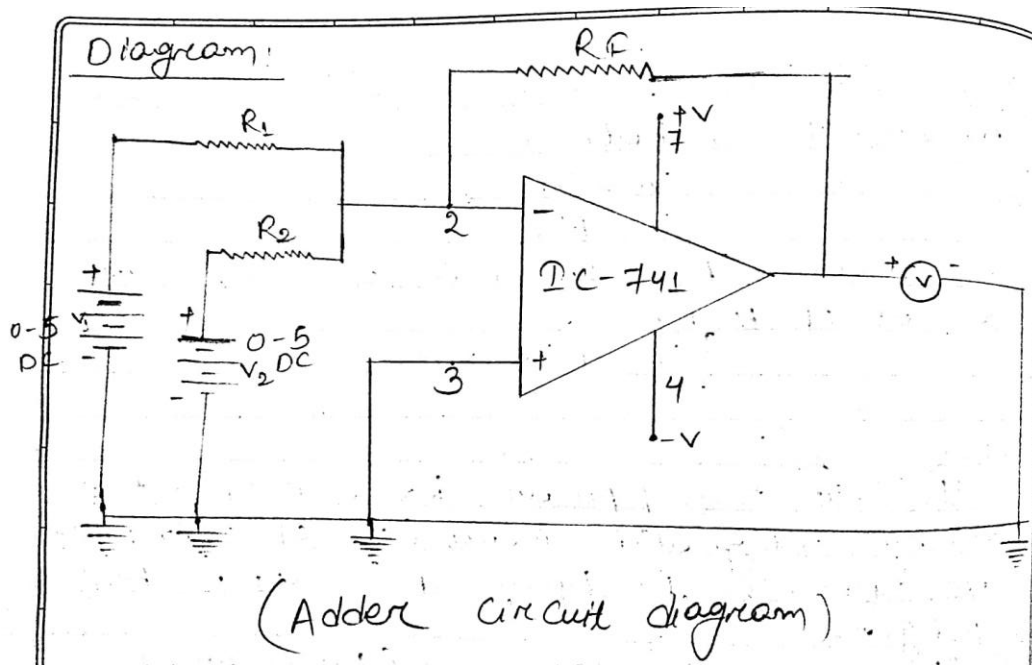



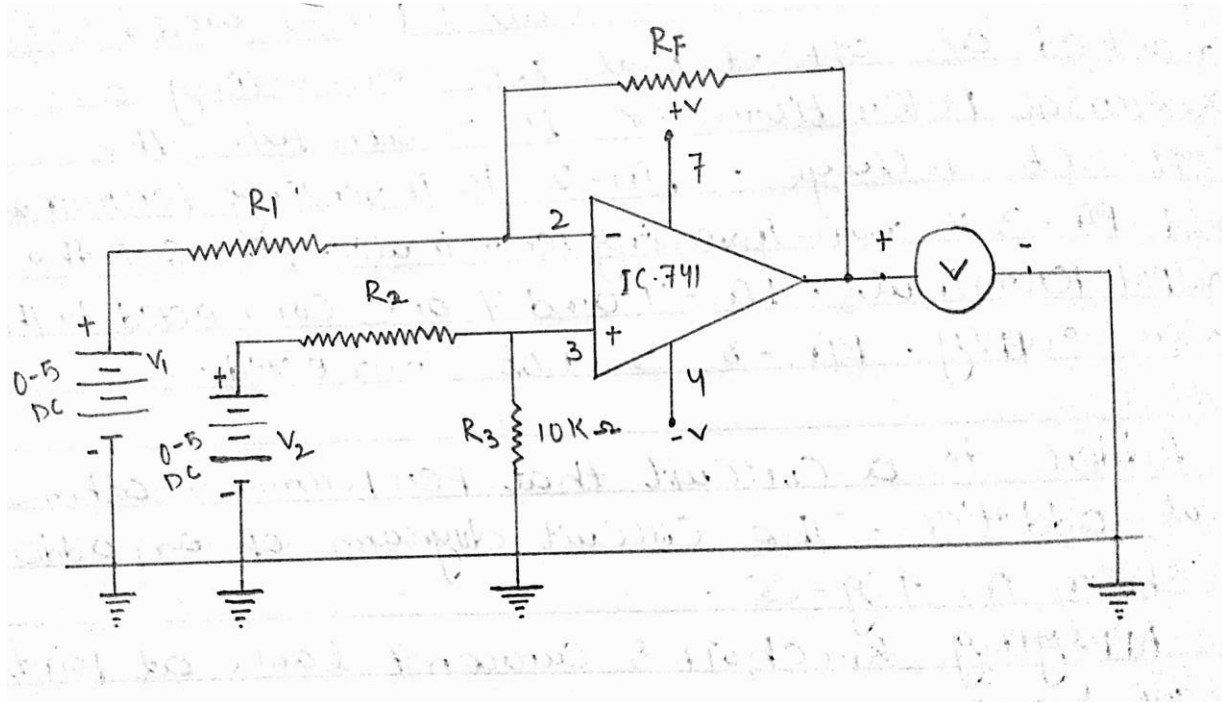

Figure – Subtractor Circuit diagram

**(a). Procedure (For Adder)**

1. Connect the circuit as shown in figure.
2. Switch on the instrument using ON/OFF toggle switch.
3. Apply input voltage of 1v from both the supplies and note down the output voltages.
4. Repeat step for different input voltages
5. Calculate the output voltage using formula

**(b). Procedure (for Subtractor)**

1. Connect the circuit as shown in figure.
2. Switch on the instrument using ON/OFF toggle switch.
3. Apply input voltage at pin no. 2, 4, 3 and note down the output voltages.
4. Calculate the output voltage using formula.

**Observation Table-**

Table -1. For Adder

S. No.	$V_1$ (volt)	$V_2$ (volt)	(Theoretical) $V_{out} = (V_1+V_2)$ (volt)	(Practical) $V_{out} = (V_1+V_2)$ (volt)
1				
2				
3				
4				
5				

Table -2. For Subtractor

S. No.	$V_1$ (volt)	$V_2$ (volt)	(Theoretical) $V_{out} = (V_2-V_1)$ (volt)	(Practical) $V_{out} = (V_2-V_1)$ (volt)
1				
2				
3				
4				
5				

**Results:**

It is clear from the table 1 and table-2 that the theoretical and practical values of output voltages are approximately equal. Hence the op-am works as an adder and subtractor.

**Precautions:-**

1. All connections should be tight.
2. Readings should be taken very carefully.

### Experiment-03 (A)

**Objective** -Study of operational amplifier (741) as integrator.

**Apparatus Required** – Bread Board, 741 IC,  $\pm 12V$  power supply, Resistors and connection wires.

**Theory and formula used**- The op-amp is a versatile device that can be used to amplify dc as well as ac input signals and was originally designed for computing such mathematical function as addition , subtraction , multiplication , differentiation and integration. With the addition of suitable external feedback components the modern day op amp can be used for a variety of applications such as ac and de signal amplification, active filters, oscillators, comparators, regulators and others.

Integrator is a circuit in which the output voltage waveform is the integral of the input voltage waveform, such a circuit is obtained by using a basic inverting amplifier configuration if the feedback resistor  $R_f$  is replaced by a capacitor  $C_f$ .

The expression for the output voltage  $V_o$  can be obtained by writing Kirchoff's current equation at node  $V_2$ :

$$I_1 = I_b + I_f$$

Since  $I_b$  is negligible small therefore  $I_1 \sim I_f$

We know that the relationship between current through and voltage across the capacitor is

$$I_c = C \, dV_c/dt$$

Therefore,

$$V_{in} - V_2/R_1 = C_f[d(V_2 - V_o)/dt]$$

However,  $V_1 = V_2 = 0$ , because A is very large.

Therefore,

$$V_{in}/R_1 = -C_f \, dV_o/dt$$

The output voltage can be obtained by integrating both sides with respect to time

$$\int_0^t \frac{V_{in}}{R_1} = \int_0^t C_f \frac{(-dv_0)}{dt} dt$$

$$= C_f(-V_0) + V_{0(t=0)}$$

Therefore,

$$V_0 = -\frac{1}{R_1 C_f} \int_0^t V_{in} dt + C \dots \dots \dots (A)$$

Where C is the integration constant and is proportional to the value of the output voltage  $V_0$  time  $t=0$  seconds. When  $V_{in} = 0$ , the integrator works as an open loop amplifier, this is because the capacitor C, acts as an open circuit ( $X_{Cf} = \infty$ ) to the input offset voltage  $V_{io}$ . In other words the input offset voltage V, and the parts of the input current charging capacitor  $C_f$ , produce the error voltage at the output of the integrator. Therefore in the practical integrator shown in fig. (2) to reduce the error voltage at the output, a resistor  $R_f$ , is connected across the feedback capacitor  $C_f$ . Thus R, limits the low frequency gain and hence minimizes the variation in the output voltage.

**Circuit Diagram-**

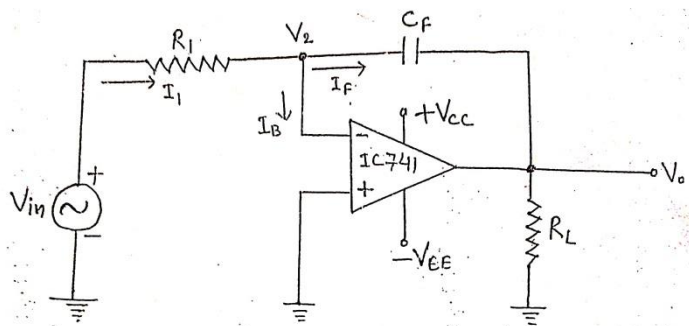

Fig(1). Basic Integrator circuit

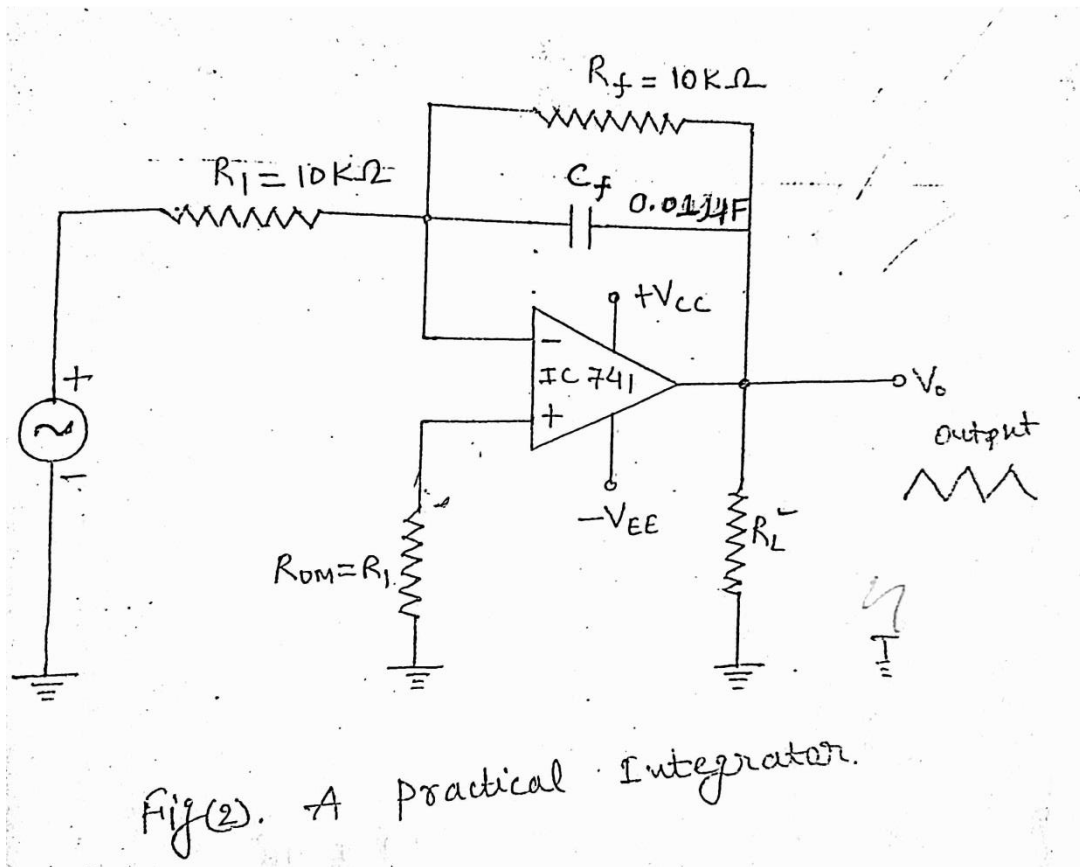

### Procedure-

1. Make the connection using bread-board and electronic components.
2. Set  $R_1 = 10\text{K}\Omega$ ,  $R_f = 10\text{K}\Omega$ ,  $R_{om} = 10\text{K}\Omega$ ,  $C_f = 0.1\mu\text{F}$ .
3. Apply the square wave input voltage  $V_{in}$  (in-built) and observe its amplitude and frequency on CRO.
4. Switch ON the unit and observe the output (triangular wave) amplitude and frequency on CRO.
5. Tabulate the amplitude and frequency of input and output by varying the frequency of the input by frequency pot.
6. Verify the results with the help of equation (A).

**Calculation:**

Input Voltage  $V_{in}$  (square wave) = .....volt (p-p)

Frequency of  $V_{in}$  = .....KHz

Output  $V_o$  (triangular wave) = ..... volt (p-p)

Frequency of  $V_o$  =..... KHz

Now,

$$V_o = -\frac{1}{R_1 C_f} \int_0^t V_{in} dt$$

= ..... volt

**Result-** It is clear from the calculation that equation (A) is verified.

**Precautions:-**

- I. All the connections should be tight.
- II. Readings of CRO should be taken very carefully.

### Experiment-03 (B)

**Objective-** Study of operational amplifier (1C741) as differentiator.

**Apparatus Required:** Op-amp. Kit, connection wires, CRO with probe

**Theory and Formula used:-** The op-amp is a versatile device that can be used to amplify dc as well as ac input signals and was originally designed for computing such mathematical function as addition, subtraction, multiplication, differentiation and integration. With the addition of suitable external feedback components the modern day op amp can be used for a variety of applications such as ac and dc signal amplification, active filters, oscillators, comparators, regulators and others.

Differentiator is a circuit that performs the mathematical operation of differentiation; that is the output voltage waveform is derivative of the input waveform. The differentiator may be constructed from a basic inverting amplifier if an input resistor  $R_1$ , is replaced by a capacitor  $C_1$

The expression for the output voltage can be obtained from Kirchhoff's current equation written at node  $V_2$ , as follows:

$$I_c = I_b = I_f$$

Since,

$$I_b = 0 \text{ therefore } I_c = I_f$$

$$V_2 - V_o / R_f = C_1 [d(V_{in} - V_2) / dt]$$

But,  $V_1 = V_2 = 0$  V (approx.), because A is very large.

Therefore,

$$-V_o / R_f = C_1 dV_{in} / dt$$

$$V_o = - R_f C_1 dV_{in} / dt \dots\dots\dots (A)$$

Thus the output  $V_o$  is equal to the  $R_f C_1$ , times the negative instantaneous rate of change of the input voltage  $V_{in}$  with time. Since the differentiator performs the reverse of the integrators

function, a cosine wave input will produce a sine wave output or a triangular input will produce a square wave output. However, the differentiator of fig (1) will not do because it practical problems. By the addition of two components  $R_1$  and  $C_f$  problems can be corrected as shown in fig. (2). This circuit is a Practical differentiator.

**Circuit Diagram:-**

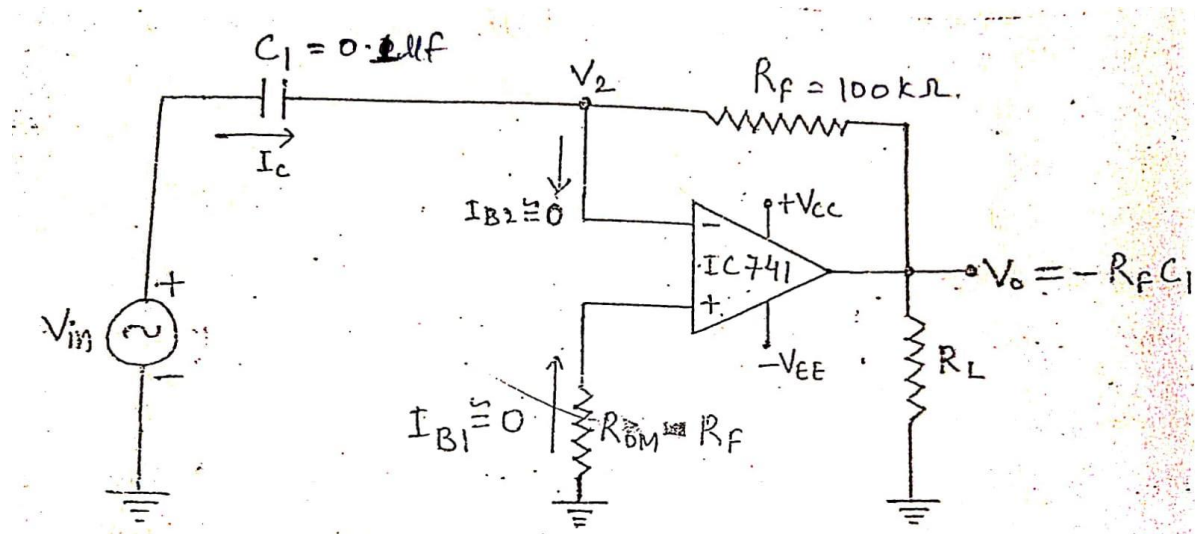

Fig(1) Basic differentiator circuit

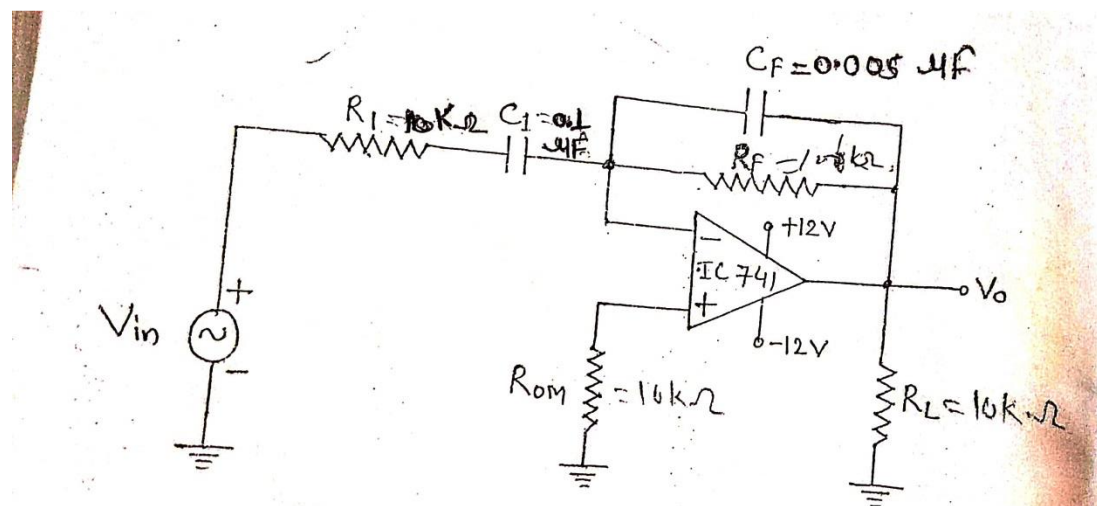

Fig.(2). A Practical differentiator



**Procedure:-**

1. Make the connection as shown in fig (2).
2. Set  $R_1 = 270\Omega$ ,  $R_f = 100K\Omega$ ,  $R_{om} = 10K\Omega$ ,  $C_1 = 0.1 \mu F$ ,  $C_f = 0.005 \mu F$ , and  $R_L = 10K\Omega$ .
3. Apply the triangular wave input voltage  $V_{in}$  (in-built) and observe its amplitude and frequency on CRO.
4. Switch on the unit and observe the output (square wave) amplitude and frequency on CRO
5. Tabulate the amplitude and frequency of input and output by varying the frequency of the input by frequency.
6. Verify the results with the help of equation (A).

**Calculation:**

Input Voltage  $V_{in}$  (triangular wave) = .....volt (p-p)

Frequency of  $V_{in}$  = .....KHz

Output  $V_o$  (square wave) = ..... volt (p-p)

Frequency of  $V_o$  = ..... KHz

Now,

$$V_o = -R_f C_1 \frac{dV_{in}}{dt}$$
$$= -(100 \times 10^3 \times 2.2 \times 10^{-6}) \frac{dV_{in}}{dt}$$
$$= \dots\dots \text{ Volt}$$

**Result-** It is clear from the calculation that equation (A) is verified.

**Precautions:-**

1. All the connections should be tight.
- II. Readings of CRO should be taken very carefully.

## Experiment – 04

**Objective -** Study the characteristics of opto electronic devices, light dependent Resistor (LDR) and light Emitting Diode (LED).

**Required apparatus:** -one DC regulated power supply of 0-3 volts, light dependent Resistor (LDR) and light Emitting Diode (LED). Voltmeter 0-3 volt DC, DC miliammeter, and one lamp with stand connection wires etc.

### Theory:-

A *Light Dependent Resistor* (LDR) or a photo resistor is a device whose resistivity is a function of the incident electromagnetic radiation. Hence, they are light sensitive devices. They are also called as photo conductors, photo conductive cells or simply photocells. They are made up of semiconductor materials having high resistance. There are many different symbols used to indicate a **LDR**, one of the most commonly used symbol is shown in the figure below. The arrow indicates light falling on it

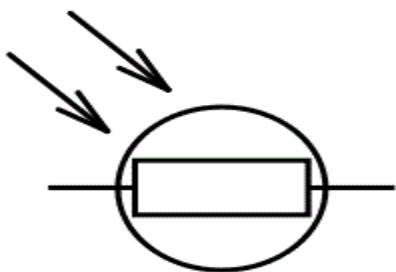

A **light dependent resistor** works on the principle of photo conductivity. Photo conductivity is an optical phenomenon in which the materials conductivity is increased when light is absorbed by the material. When light falls i.e. when the photons fall on the device, the electrons in the valence band of the semiconductor material are excited to the conduction band. These photons in the incident light should have energy greater than the band gap of the semiconductor material to make the electrons jump from the valence band to the conduction band. Hence when light having

enough energy strikes on the device, more and more electrons are excited to the conduction band which results in large number of charge carriers. The result of this process is more and more current starts flowing through the device when the circuit is closed and hence it is said that the resistance of the device has been decreased. This is the most common **working principle of LDR**.

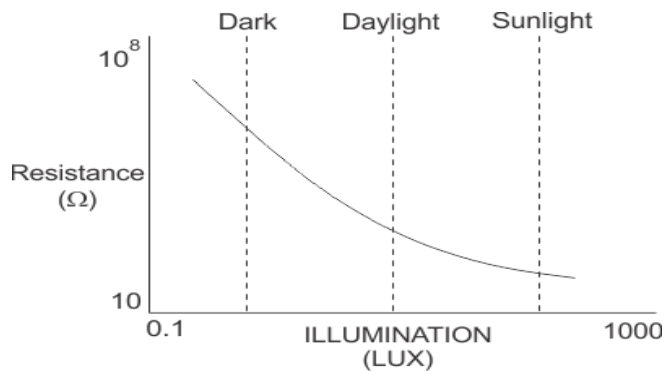

#### Procedure:-

1. Connect the output of DC power supply (0-3 VDC) to the input of the LDR circuit. Also connect voltmeter, current meter and LDR in the circuit through patch cords shown by dotted lines.
2. Place the lamp holder and LDR on a graduated wooden stand opposite to each other. Connect the lamp to AC mains and focus the light on LDR. Select the range of current meter to 5mA.
3. Switch on the instrument (power supply unit) using ON/OFF toggle switch provided on the front panel.
4. Now increase the power supply voltage in small step and every time note down the voltage & current in observation table. Calculate the resistance value of LDR by using formula  $R = V/I$
5. Vary the distance (d) between LDR & light source and repeat the experiment again.
6. Plot a graph between resistance (R) vs Distance (d<sup>2</sup>, SQUIRE).
7. also note down the current (mA) for different distances between LDR & light source for fixed voltage.

#### Observation table for LDR

S,no.	Distance of lamp from LDR d cm	Voltmeter reading v volt	Milliammeter reading (I) mA	Resistance of LDR $R = V/I$	D2 cm <sup>2</sup>
1					
2					
3					

### **Light Emitting Diode (LED).**

They are the most visible type of diode that emit a fairly narrow bandwidth of either visible light at different colored wavelengths, invisible infra-red light for remote controls or laser type light when a forward current is passed through them.

The “Light Emitting Diode” or LED as it is more commonly called, is basically just a specialized type of diode as they have very similar electrical characteristics to a PN junction diode. This means that an LED will pass current in its forward direction but block the flow of current in the reverse direction.

Light emitting diodes are made from a very thin layer of fairly heavily doped semiconductor material and depending on the semiconductor material used and the amount of doping, when forward biased an LED will emit a colored light at a particular spectral wavelength.

When the diode is forward biased, electrons from the semiconductors conduction band recombine with holes from the valence band releasing sufficient energy to produce photons which emit a monochromatic (single color) of light. Because of this thin layer a reasonable number of these photons can leave the junction and radiate away producing a colored light output.

### **light emitting diode construction**

LED Construction

Then we can say that when operated in a forward biased direction Light Emitting Diodes are semiconductor devices that convert electrical energy into light energy.

The construction of a Light Emitting Diode is very different from that of a normal signal diode. The PN junction of an LED is surrounded by a transparent, hard plastic epoxy resin hemispherical shaped shell or body which protects the LED from both vibration and shock.

Surprisingly, an LED junction does not actually emit that much light so the epoxy resin body is constructed in such a way that the photons of light emitted by the junction are reflected away from the surrounding substrate base to which the diode is attached and are focused upwards through the domed top of the LED, which itself acts like a lens concentrating the amount of light. This is why the emitted light appears to be brightest at the top of the LED.

However, not all LEDs are made with a hemispherical shaped dome for their epoxy shell. Some indication LEDs have a rectangular or cylindrical shaped construction that has a flat surface on top or their body is shaped into a bar or arrow. Generally, all LED's are manufactured with two legs protruding from the bottom of the body.

Also, nearly all modern light emitting diodes have their cathode, ( - ) terminal identified by either a notch or flat spot on the body or by the cathode lead being shorter than the other as the anode ( + ) lead is longer than the cathode (k).

Unlike normal incandescent lamps and bulbs which generate large amounts of heat when illuminated, the light emitting diode produces a "cold" generation of light which leads to high efficiencies than the normal "light bulb" because most of the generated energy radiates away within the visible spectrum. Because LEDs are solid-state devices, they can be extremely small and durable and provide much longer lamp life than normal light sources.

### **Light Emitting Diode Colours**

So how does a light emitting diode get its colour. Unlike normal signal diodes which are made for detection or power rectification, and which are made from either Germanium or Silicon semiconductor materials, **Light Emitting Diodes** are made from exotic semiconductor compounds such as Gallium Arsenide (GaAs), Gallium Phosphide (GaP), Gallium Arsenide Phosphide (GaAsP), Silicon Carbide (SiC) or Gallium Indium Nitride (GaInN) all mixed together at different ratios to produce a distinct wavelength of colour.

Different LED compounds emit light in specific regions of the visible light spectrum and therefore produce different intensity levels. The exact choice of the semiconductor material used will determine the overall wavelength of the photon light emissions and therefore the resulting colour of the light emitted.

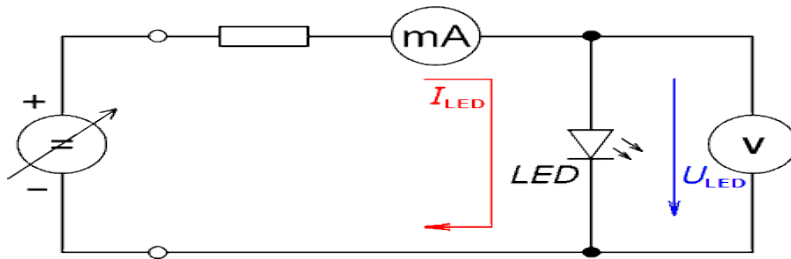

**Procedure:-**

1. Connect the output of DC power supply (0-3 VDC) to the input of the LED circuit. Also connect voltmeter, current meter in the circuit through patch cords shown by dotted lines.
2. Switch on the instrument (power supply unit) using ON/OFF toggle switch provided on the front panel.
3. Now increase the power supply voltage in small step and every time note down the voltage & current in observation table.
4. Plot a graph between voltage and current by taking voltage along X axis and current along Y axis.

**Observation table for LED:-**

s.no.	Forward voltage (V)	Forward current (I)
1		
2		
3		
4		
5		

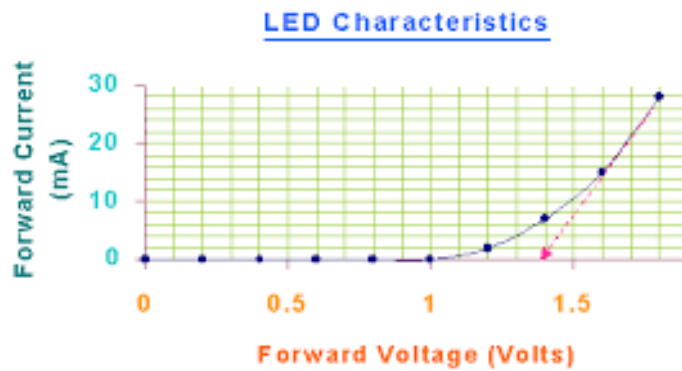

**Result:-** 1. forward resistance of LDR is .....and forward resistance of LED is.....  
 2 Voltage ..... & current ..... LED start Glow, Voltage ..... & current ..... LED fully Glow.

**Precautions:-**

1. Firstly read about complete experiment then perform.
2. Connect circuit properly according to diagram.
3. Check connecting wires before use.
4. Connect current meter in series only.

## Experiment-05

**Objective :-** Study of I-V Characteristic of a solar cell.

**Required apparatus:-** Solar cell mounted on the front panel in a metal box with connections brought out on terminals. Two meters mounted on the front panel to measure the solar cell voltage and current. Different types of load resistances selectable using band switch also provided on the front panel. Patch chords for connections. A lamp holder with 100 watt lamp.

**Theory and formula used:-**

The solar cell is a semiconductor device, which converts the solar energy into electrical energy. It is also called a photovoltaic cell. A solar panel consists of numbers of solar cells connected in series or parallel. The number of solar cell connected in a series generates the desired output voltage and connected in parallel generates the desired output current. The conversion of sunlight (Solar Energy) into electric energy takes place only when the light is falling on the cells of the solar panel. Therefore in most practical applications, the solar panels are used to charge the lead acid or Nickel-Cadmium batteries. In the sunlight, the solar panel charges the battery and also supplies the power to the load directly. When there is no sunlight, the charged battery supplies the required power to the load

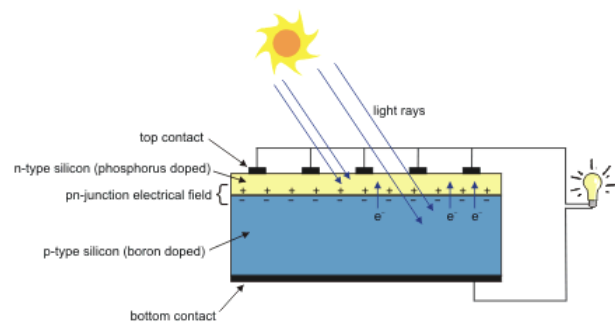
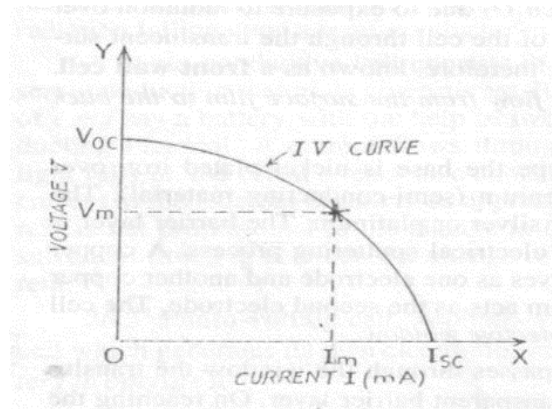

**Fig. 1a** Working principle of a solar.

A solar cell operates in somewhat the same manner as other junction photo detectors. A built-in depletion region is generated in that without an applied reverse bias and photons of adequate energy create hole-electrons pairs. In the solar cell, as shown in Fig. 1a, the pair must diffuse a considerable distance to reach the narrow depletion region to be drawn out as useful current. Hence, there is higher probability of recombination. The current generated by separated pairs



increases the depletion region voltage (Photovoltaic effect). When a load is connected across the cell, the potential causes the photocurrent to flow through the load.



**Fig. 1b** V-I Characteristics

The e.m.f. generated by the photo-voltaic cell in the open circuit, i.e. when no current is drawn from it is denoted by VOC (V-open circuit). This is the maximum value of e.m.f.. When a high resistance is introduced in the external circuit a small current flows through it and the voltage decreases. The voltage goes on falling and the current goes on increasing as the resistance in the external circuit is reduced. When the resistance is reduced to zero the current rises to its maximum value known as saturation current and is denoted as ISC, the voltage becomes zero. A V-I characteristic of a photovoltaic cell is shown in Fig. 1b.

The product of open circuit voltage VOC and short circuit current ISC is known as ideal power.

$$\text{Ideal Power} = \text{VOC} \times \text{ISC}$$

The maximum useful power is the area of the largest rectangle that can be formed under the V-I curve. If Vm and Im are the values of voltage and current under this condition, then

$$\text{Maximum useful power} = \text{Vm} \times \text{Im}$$

$$\therefore \text{Fill factor} = \frac{V_m \times I_m}{V_{OC} \times I_{SC}}$$

The ratio of the maximum useful power to ideal power

### Circuit diagram-

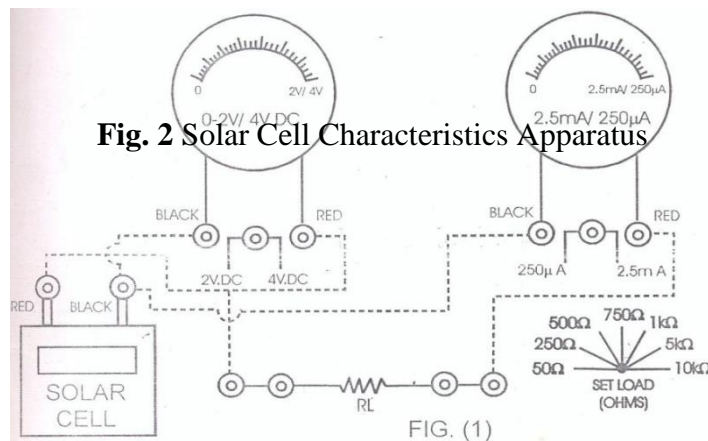

### Procedure-

#### When experiment is performed with 100 Watt lamp:

1. Place the solar cell and the light source (100 watt lamp) opposite to each other on a wooden plank. Connect the circuit as shown by dotted lines (Fig. 2) through patch chords.
2. Select the voltmeter range to 2V, current meter range to 250µA and load resistance (RL) to 50Ω.
3. Switch ON the lamp to expose the light on Solar Cell.
4. Set the distance between solar cell and lamp in such a way that current meter shows 250 µA. deflections. Note down the observation of voltage and current in Table 1.
5. Vary the load resistance through band switch and note down the current and voltage readings every time in Table 1.
6. Plot a graph between output voltage vs. output current by taking voltage along X-axis and current along Y-axis.

**Observation:-**

S. No.	Voltage	Current	Load Resistance (RL)
1.			
2.			
3.			
4.			
5.			

**Table 1**

From the Graph:

Value of  $V_m = \dots$  volts

Value of  $I_m = \dots$  mA

Maximum useful power =  $V_m \times I_m$  mW

Ideal power  $V_{OC} \times I_{SC} = \dots$  mW

$$\therefore \text{Fill factor} = \frac{V_m \times I_m}{V_{OC} \times I_{SC}} =$$

**Precautions:**

1. The solar cell should be exposed to sun light before using it in the experiment.
2. Light from the lamp should fall normally on the cell.
3. A resistance in the cell circuit should be introduced so that the current does not exceed the safe operating limit.

## Experiment-06

### **Aim:-**

- 1) To plot the current-voltage characteristics of a CdS photo-resistor at constant irradiance.
- 2) To measure the photo-current as a function of the irradiance at a constant voltage.

**Appartus :-** INDOSAW SK007

### **Introduction:-**

When light radiations fall on the insulating crystal, an increase in electrical conductivity of the crystal takes place. This phenomenon is called photoconductivity. Gudden and Pohl did a lot of research work on photoconductivity. They found that:

- a) For a given material there was a similar dependence of light absorption and the extinction of photoconductivity by light on the wavelength of light.
- b) The presence of impurities extended the region of photosensitivity to longer wavelengths.
- c) Some impurities when incorporated could reduce photosensitivity of the material. Direct effect of illumination is to increase the number of mobile charge carriers in the crystal.

### **Theory:-**

When the energy of the incident photon exceeds the energy gap  $E_g$ , free electron-hole pairs are produced in the crystal due to the absorption of the incident photons. The electrons and holes serve as the carriers of the electrical conductivity. The electrons are in the conduction band and the holes in the valence band of the crystal. Therefore photoconductivity arises due to the reason that the incident photons excite the electrons from the valence band into conduction band where they become mobile and creation of holes in the valence band where they are also mobile.

It may be pointed out that photo-conduction is not an intrinsic phenomenon. The impurities and imperfections in the crystal also contribute to the photoconductivity. If donor/acceptor impurities are present, then even the photons having energy below the threshold for the production of electron-hole pairs may be able to produce mobile electrons or holes.

The role of imperfections is quite important in understanding the phenomenon of photoconductivity. Due to imperfections, discrete energy levels are introduced in the forbidden energy gap. These are called traps.

Thus, photoconductivity is a process in which electrons ( or holes ) are freed one or other types of bound state by photons, spend some time in the conduction band ( or valence band ) in which they act current carries and are finally recaptured by the traps. As soon as the incident radiation is removed, photconductivity disappears because the holes and electrons recombine with each other.

### **Variation of photoconductivity with illumination:-**

Let us suppose that electron-hole pairs are produced uniformly throughout the volume of the crystal by irradiation with an external light source. Recombination occurs by direct combination of electrons with holes. It may be assumed that electrons leaving the crystal at one end are replaced by electrons flowing in from the opposite electrode. The mobility of holes may be neglected in comparison with the mobility of the electrons.

Photoconductivity may be written as

$$\sigma = n_0 e \mu \quad (1)$$

where,  $\mu$  is the electron mobility and  $n_0$  is the electron concentration in the steady state. At a given voltage, the photo-current varies with light intensity as  $L^{1/2}$ , where  $L$  is the number of photon absorbed per unit volume of the specimen per unit time. The exponent observed may be usually between  $1/2$  and 1, with some crystal having higher exponent. In case of CdS crystal, the exponent varies between 0.92 at low level and 0.58 at high level of illumination. The response time is given by

$$t_0 = n_0 / L$$

from equation (1) we get

$$n_0 = \sigma / e \mu$$

$$t_0 = \sigma / e \mu L \quad (2)$$

Response time is the time during which carrier concentration should drop to 0.5m Response time should therefore be directly proportional to the photoconductivity at a given illumination level L. Sensitive photo-conductors should have long response time.

### **Effect of traps**

A trap is an impurity atom or other imperfection in the crystal capable of capturing an electron or hole. The captured carrier may be re-emitted at a subsequent time and may move to another trap. There are two types of traps:

- 1) One type helps in recombination of holes & electrons and thus to restore thermal equilibrium. These traps are called as recombination centres. Recombination takes place at much higher rate in the presence of traps.
- 2) Second type of traps affect mainly the freedom of motion of charge carriers of one sign or the other. It is observed therefore, that the presence of traps reduces the conductivity and also reduces the response time.

### **Space charge effects**

In photo-conductors, space charges arise when the illumination is not uniform throughout the crystal or when the electrodes cannot supply charge carriers freely in the crystal. The photo-currents may be reduced effectively and ultimately stop flowing when the electric field of the surface charges just cancels the field applied by the electrodes.

### **Procedure**

- 1) Mount the lamp housing (H), adjustable slit self-centering (A), polarizer (P<sub>1</sub>), analyzer



(P<sub>2</sub>), lens (L<sub>1</sub>) and photo-resistor (R) on the optical bench as shown in fig 1.

Fig.-(1)

- 2) Connect the leads of the lamp housing to the power supply (0-12V AC/DC, 6 Amp.) and apply 10 V AC to the lamp.
3. Adjust the heights of the lamp, housing, adjustable slit self-centering, polarizer, analyzer, lens and photo-resistor such that all of them lie on same optical axis.
4. Make the connections to the photo-resistor and multimeter as shown in fig.2

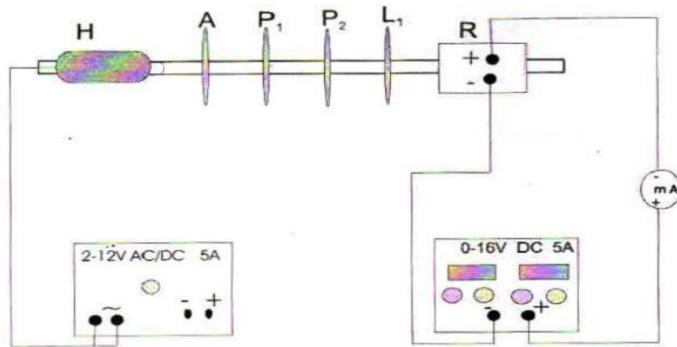

Fig.-(2)

5. Initially set the polarizer and analyzer at  $0^\circ$  mark.
6. Adjust the lamp, lens and photo-resistor so that a homogeneous ray of light illuminates the photo resistor.
7. Set the voltage of DC power supply (0-16 VDC, 5 Amp.) to 12V.
8. Adjust the width of the self centering adjustable slit so that a current of about 9 mA flows through the photo-resistor. Keep the width of the slit fixed for the experiment.

Note: When the illumination is changed, the response of the photo-resistor is slow it takes some time until the new value of the resistance is reached. Before noting the values, wait until a stationary state is reached.

- a) Measuring the photo-current  $I_{ph}$ , as a function of the voltage  $U$  at a constant irradiance

- 1) Set the analyzer at  $0^\circ$  mark provided on the analyzer.
- 2) Interrupt the path of the ray of light and determine the photo-current  $I_o$ , due to residual lightness.
- 3) Starting from 16V, reduce the voltage U to 0V In steps of 2 V. Measure the photo-current  $I_{ph}$ , each time and record it.
- 4) Repeat the series of measurements with analyzer at  $30^\circ$ ,  $60^\circ$  and  $90^\circ$ .

b) Measuring the photo-current  $I_{ph}$ , as a function of the Irradiance at a constant voltage U

- (1) Set the voltage U to 16 V, Interrupt the path of the ray of light and measure the photo-current  $I_o$ , due to residual lightness.
- (2) In order to vary the irradiance, Increase the angle between the polarization planes of the polarizers in steps of  $10^\circ$  from  $0^\circ$  to  $90^\circ$ . Measure the photo-current  $I_{ph}$  each time and record it.
- (3) Repeat the series of measurements at  $U=8V$  and  $U=1 V$ .

Note: The photo-resistor is influenced even by slight residual lightness in the experiment room. The experiment must be performed in a dark room.

### Observations:-

1) Measuring photo current I as a function of Voltage U at a constant Irradiance:

U (V)	$I_{ph}$ at $0^\circ$ (mA)	$I_{ph}$ at $30^\circ$ (mA)	$I_{ph}$ at $60^\circ$ (mA)	$I_{ph}$ at $90^\circ$ (mA)
16	9.75	5.63	3.08	0.93
14	8.43	4.92	2.70	0.81
12	7.27	4.21	2.29	0.69
10	5.82	3.47	1.89	0.57
8	4.57	2.74	1.50	0.45
6	3.24	2.03	1.10	0.33
4	2.00	1.35	0.74	0.22
2	0.77	0.69	0.37	0.11



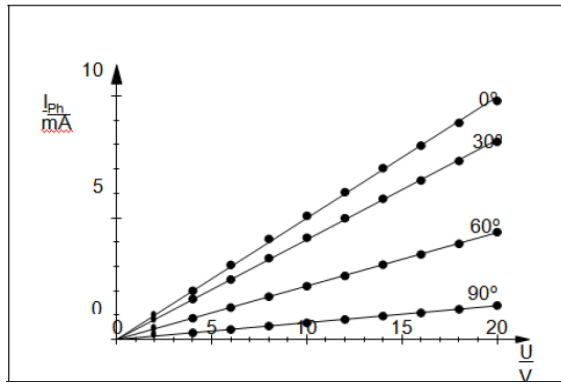
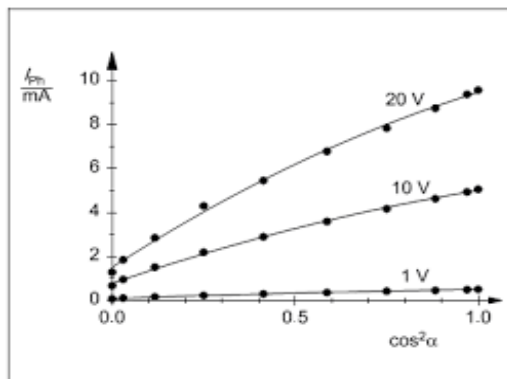

Fig. 3 Current–Voltage characteristics of CdS photoresistor

2) Measuring photo current as a function of Irradiance  $\alpha$  at a constant voltage  $U$ :

$\alpha$	$\text{Cos}^2 \alpha$	$I_{ph}$ at 16V (mA)	$I_{ph}$ at 8V (mA)	$I_{ph}$ at 1V (mA)
$0^\circ$	1.00	9.73	4.68	0.57
$10^\circ$	0.97	9.19	4.47	0.54
$20^\circ$	0.88	8.61	4.19	0.51
$30^\circ$	0.75	7.70	3.75	0.49
$40^\circ$	0.59	6.68	3.23	0.39
$50^\circ$	0.41	5.25	2.55	0.33
$60^\circ$	0.25	3.92	1.89	0.24
$70^\circ$	0.12	2.57	1.23	0.15
$80^\circ$	0.03	1.50	0.71	0.09
$90^\circ$	0.00	1.11	0.53	0.06



**Result :-** The CdS photo-resistor behaves like an ohmic resistance that depends upon the irradiance.

## Experiment No:- 07

**Aim:-** A-simple power-supply design for low-voltage DC

**Aparartus required:-** 1 Step down transformer, 4 diode 1 electrolytic capacitor, 2 simple/ ceramic capacitor, 2 regulator IC 78XX/79XX series, 1 resistor, 1 LED, 1 bread board, 1 Multimeter, some wires etc.

### Introduction & theory:-

Every electronics project runs on a power-source of some kind. Unless you're messing with batteries (and even then) there's a good chance you'll require a power-regulation circuit like the one presented below:

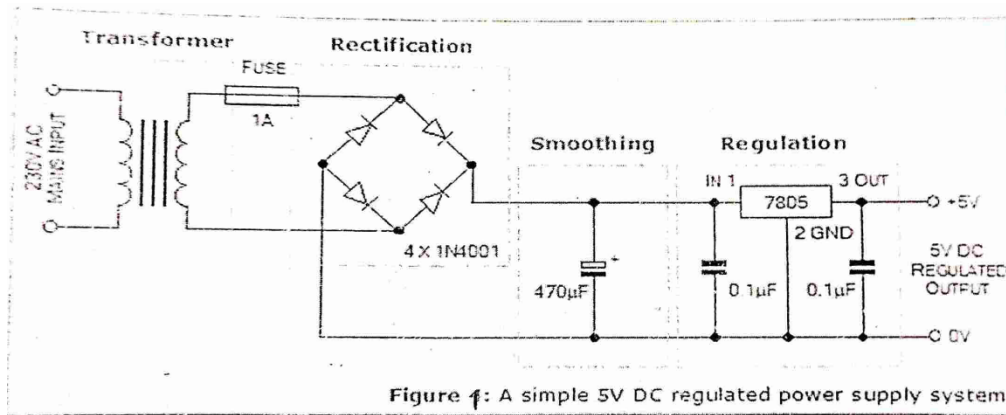

### Block Diagram

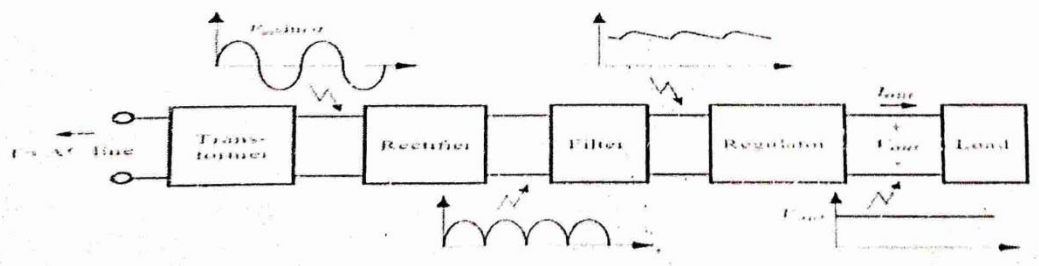

This design is based around 4 main parts. A transformer (optional in case of DC-input voltage) a bridge rectifier, a smoothing capacitor and the LM78XX chip which contains a 'linear voltage regulator'. This article will explain what they all do, how it works (kinda), how to design-and-build one and will present some considerations concerning the user of these devices. The design is split up in a part that concerns itself with transforming AC into DC and a part that explains just how to regulate the DC part with the LM78xx chip. For this reason the design will also be of

Interest if you are simply looking to transform a DC voltage into a lower voltage to fit our circuit.

The problem

Let's say we have a little circuit that we would like to make but it requires 5volt DC power. Unless we can find some pre-made power-supply somewhere, we might have to build our own little power-supply circuit too. Even if we are not faced with the task of going from AC-voltage to DC-voltage ourselves, we might still need to regulate the voltage to get it to be the required 5Vdc instead of, say, 12Vdc that we get from a lead-battery.

In the rest of the article we're going to assume that we want a 5Volt powersupply like the one presented in the figure above. We're going to see how we could build it all from scratch, right down from going to 5Vde from a wall-socket with 240Vac. Also, we're going to show what part can be left out if you already have 12Vde (from a lead battery, for example).

### Getting from AC to DC

As you might know, electric power is available in both AC and DC flavors. The distinction between the two is that with DC, the 'voltage' or 'potential' between the two poles of the supply is at a steady level.

Let's say, 5Vdc. Looking at it with an oscilloscope would reveal a single straight line with nothing interesting happening. With AC power, the potential between the two poles oscillates between two extremes at a fixed frequency; normally 50 or 60 Hz, depending on where you live. The reason for this is explained further in AC, but it's sufficient to realize that it is easier to transform high AC voltages into lower AC voltages than it is to transform high DC voltages into low DC voltages.

For that reason, if you're given an AC-voltage, you will need some way of turning it into lower AC voltage first, and then turning it into-a-DC-voltage. This is where the AC transformer and bridge rectifier come in. Please consider the circuitc presented earlier.

The transformer these is a device which uses two copper-wire coils wound around a single metal frame to create a électro-magnetic way of transferring power from one coil to the other. The ratio between the windings on first coil and the second coil determine what voltage comes out of the 'secondary coil when you put some potential (say, 240Vac) on the primary coil.

A fuse is positioned in between the transformer and the next part, the rectifier, to burn through when too much current has been drawn from the circuit; protecting the parts of the power-supply against overload. Essentially It's just a thin wire that will burn through if too much current runs through it, it doesn't do anything to the voltage or the waveform that comes from the transformer. The frequency and waveform of the AC-voltage coming out of the secondary side

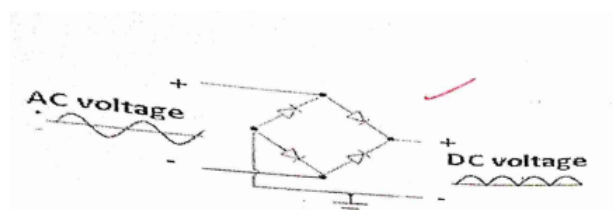

of the transformer will be the same as that of the primary side, except at a different voltage. That voltage, however, still needs to be turned into something resembling DC before we can hope to use it for most DC-based electronics.

For this purpose we require the bridge rectifier. This is a simple circuit made out of four diodes (in this case of a popular type, the In4007) configured in such a way (see diagram) that it will basically 'flip' the negative parts of the AC waveform (see diagram above) and put them on the positive side of the graph. This works because diodes only conduct in one direction and like a broken connection when the polarity is reversed. This results in a fluctuating/oscillating potential between the two outputs of the bridge rectifier circuit that has one pin always be 'positive' in respect to the other output terminal. See the diagram on how this looks. Note that the bridge rectifier can also be bought as a single component with four pins sticking out of it, containing the correct configuration of four diodes inside of it, internally. After we've achieved the task of making one terminal be positive with respect to the other terminal, we can now take on the task of smoothing away the oscillation. As it is , using this voltage as it is would make parts like logic-gates severely unhappy, not to mention add an incredible buzzing sound to anything that has a speaker connected to it.

### **Smoothing the waveform**

To get from the bumpy waveform shown above to something that 'comes close' to something we can work with. please consider the diagram below.

Shown Here is the large capacitor (470uf in the original circuit) and a picture of what the waveform will look approximately look like if you'd look on an oscilloscope. A capacitor is a part that acts somewhat like a sponge or a reservoir for voltage. It will suck up energy while it's own charge is lower than what's being provided on it's terminals. It will supply energy TO the terminals when the reverse is the case, providing it's energy to the terminals. The specific type of capacitor used in this circuit is an 'electrolytic capacitor' or 'elco' because of the rather "high" level of capacity required for this circuit (470 micro Farad). We will find that varying designs for this circuit use different values, just make sure it's at least larger than, say, 100 $\mu$ F and can withstand the voltage-levels you're using (in the case of a 12V supply, a 16Volt model is not a bad idea). Note that these types of capacitors and 'tantalum' models are POLAR, and need to be connected the right way around. Markings on the side of the part will show you what is + and -.

Other capacitors (like the others in this circuit) are not as large and they are available in non-polar versions.

This results in the smoothing demonstrated above. It is not quite a straight line yet, but you will notice that the voltage does no longer drop below a certain point anymore. This allows us to now limit the voltage to the required level by use of the next parts in our circuit.

## The LM78xx series

This part might look like a transistor to the inexperienced observer; however this three-pin part houses a full (however simple) linear voltage regulator. What this means is that it has a way of turning a DC voltage into a lower voltage. In this circuit we use the 7805; the member of this series which can handle input-voltages of 7-20VDC and return a stable 5Volt on it's output- pin.

The way this works is that it basically 'short-circuits' any over-voltage to the middle pin, which is connected to ground (the in the circuit) and turns that into heat. In essence, all the power it has no use for is turned into waste heat. We'll discuss further on below what implications this has for how much current you can draw from this power-supply and how it affects efficiency.

The two small capacitors on either side (0.1 $\mu$ F or 100 $\mu$ F), on either side of the 7805 are put there to counter troubles when connecting this power-supply to some circuit which deals with high-frequency switching of anything that draws power. Think of connecting a little microprocessor that switches a lot of LED's on and off at a high frequency; perhaps even employing pwm to dim them.

What might happen is that the current-draw of the circuit connected to this power-supply might make the voltage drop just a little for a moment. The voltage-regulator will work to compensate, but it takes a little time for it to do this. While it's adjusting, the current-draw might change again and in fact have the opposite effect. Compensating again, it'll adjust... etc. However, if the time for the regulator to do all this coincides with the frequency of the load- changes, it might end up re-enforcing each other.

### Considerations/warnings

The LM78XX series comes a package called 'TO-220'. A picture and the pinout of the LM7805

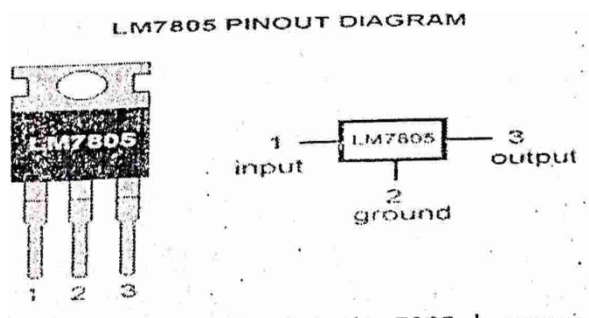

is shown below:

The part used in our circuit is the 7805; however different models exist that limit the output-voltage to other levels. Helpfully, they are labelled accordingly. A 7812 wil limit the output to

12Volt, etc. Many manufacturers produce parts with the 78xx name on it; not all start with 'LM' before it, yet all seem to have grossly the same operating specs, as well as the same pinout.

One thing that all the 'normal' versions of this circuit have in common is that they all require at least (about) 1.5V over-voltage to function. What this means is that you can only get 5Volt if you put at least 6.5Volt In. It would be good to never cut it that close, either, and always provide some extra voltage just in case there are fluctuations on the input voltage.

There are however low-drop' versions available are a lituo higher cost that require less over-voltage; some as low as 0.3Volt.

All of these parts are able to provide up to 1Amp of output-current. It is good to realize that they only succeed in handling that current if you make sure they can keep cool properly. Remember they 'burn' all the excess energy into warmth and thus risk overheating if not provided with a heatsink of some kind. Simply screwing a sheet of metal to the back will help enough. Without a heatsink, drawing more than 500mA from them will result in trouble.

A smaller version of the 78XX series called the 78IXX series; only able to supply 100mA at maximum but are much smaller and a little cheaper.

For all these parts there is one consideration that they all have in common that relates to their (In)efficiency when supplying them with (too high) Input voltages and how their inefficiencies increase as you draw more current from them.

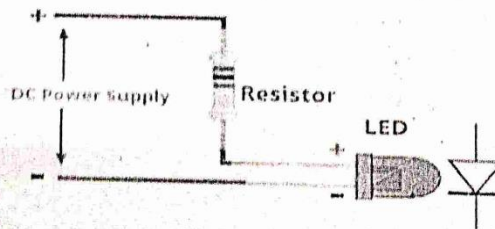
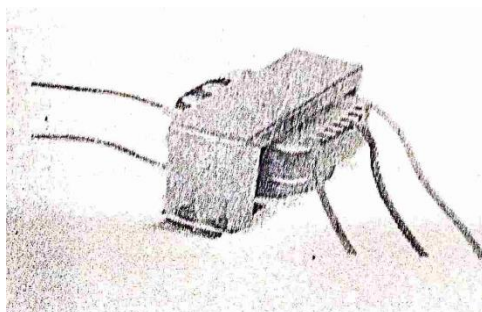
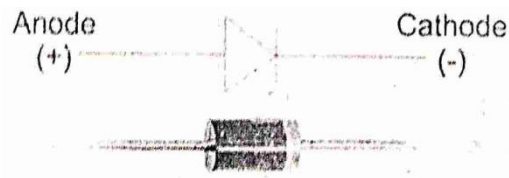
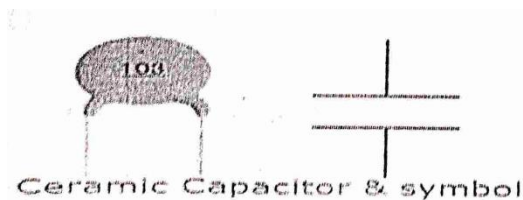
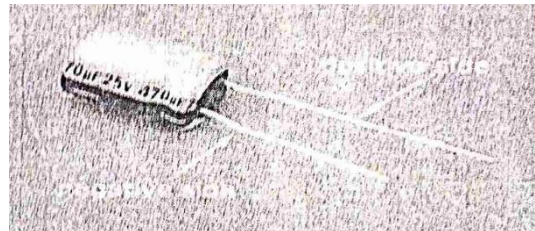
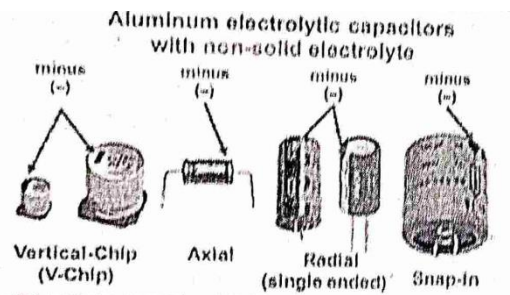

Observations:

S.No.	Paramertes	Values with units
1	Output voltage of transformer secondary AC voltage	
2	Output of rectifier DC voltage	
3	Output of rectifier AC voltage	
4	Output of Filter DC voltage	
5	Input of regulator IC	
6	Output of regulator IC	

**Precautions:-**

- 1) Do not touch primary of transformer.
- 2) Connect circuit as per diagram.
- 3) Use multimeter very carefully.



## Experiment No:- 08

**Aim:-** Verification of De-Morgan's Theorem.

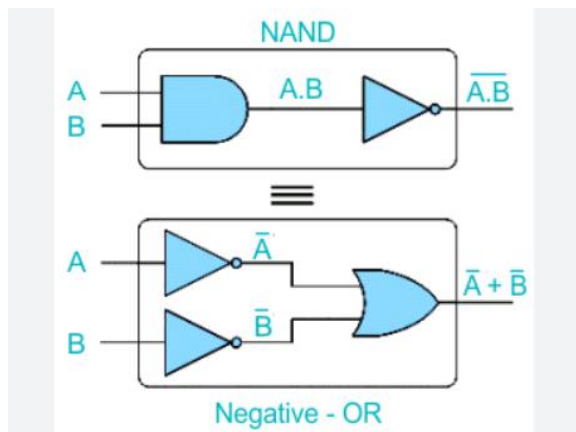

### **DeMorgan's Theorem**

DeMorgan's Theorem and Laws can be used to find the equivalency of the NAND and NOR gates.

As we have seen previously, Boolean Algebra uses a set of laws and rules to define the operation of a digital logic circuit with "0's" and "1's" being used to represent a digital input or output condition. Boolean Algebra uses these zeros and ones to create truth tables and mathematical expressions to define the digital operation of a logic AND, OR and NOT (or inversion) operations as well as ways of expressing other logical operations such as the XOR (Exclusive-OR) function.

While George Boole's set of laws and rules allows us to analyse and simplify a digital circuit, there are two laws within his set that are attributed to **Augustus DeMorgan** (a nineteenth century English mathematician) which views the logical NAND and NOR operations as separate NOT AND and NOT OR functions respectively.

But before we look at **DeMorgan's Theory** in more detail, let's remind ourselves of the basic logical operations where A and B are logic (or Boolean) input binary variables, and whose values can only be either "0" or "1" producing four possible input combinations, 00, 01, 10, and 11.



## Truth Table for Logical Operation

DeMorgan's Theorem and Laws

A	B	AND	NAND	OR	NOR
0	0	0	1	0	1
0	1	0	1	1	0
1	0	0	1	1	0
1	1	1	0	1	0

The following table gives a list of the common logic functions and their equivalent Boolean notation where a "." (a dot) means an AND (product) operation, a "+" (plus sign) means an OR (sum) operation, and the complement or inverse of a variable is indicated by a bar over the variable.

Logic Function	Boolean Notation
AND	$A.B$
OR	$A+B$
NOT	$\bar{A}$
NAND	$\overline{A.B}$
NOR	$\overline{A+B}$

## DeMorgan's Theory

*DeMorgan's Theorems* are basically two sets of rules or laws developed from the Boolean expressions for AND, OR and NOT using two input variables, A and B. These two rules or theorems allow the input variables to be negated and converted from one form of a Boolean function into an opposite form.

DeMorgan's first theorem states that two (or more) variables NOR'ed together is the same as the two variables inverted (Complement) and AND'ed, while the second theorem states that two (or more) variables NAND'ed together is the same as the two terms inverted (Complement) and

OR'ed. That is replace all the OR operators with AND operators, or all the AND operators with an OR operators.

### DeMorgan's First Theorem

DeMorgan's First theorem proves that when two (or more) input variables are AND'ed and negated, they are equivalent to the OR of the complements of the individual variables. Thus the equivalent of the NAND function and is a negative-OR function proving that  $\overline{A \cdot B} = \overline{A} + \overline{B}$  and we can show this using the following table.

$$\overline{A \cdot B} = \overline{A} + \overline{B}$$

### Verifying DeMorgan's First Theorem Truth Table

Inputs		Truth Table Outputs For Each Term				
B	A	A.B	$\overline{A \cdot B}$	$\overline{A}$	$\overline{B}$	$\overline{A} + \overline{B}$
0	0	0	1	1	1	1
0	1	0	1	0	1	1
1	0	0	1	1	0	1
1	1	1	0	0	0	0

We can also show that  $\overline{A \cdot B} = \overline{A} + \overline{B}$  using logic gates shown.

### DeMorgan's First Law Implementation using Logic gates

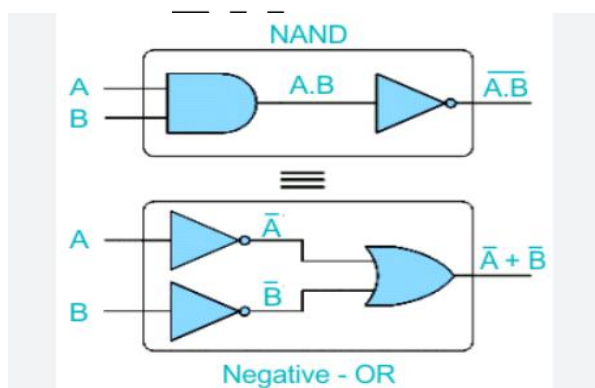

The top logic gate arrangement of:  $\overline{A \cdot B}$  can be implemented using a NAND gate with inputs A and B. The lower logic gate arrangement first inverts the two inputs producing  $\overline{A}$  and  $\overline{B}$  which become the inputs to the OR gate. Therefore the output from the OR gate becomes:

$$\overline{A} + \overline{B}$$

Thus an OR gate with inverters (NOT gates) on each of its inputs is equivalent to a NAND gate function, and an individual NAND gate can be represented in this way as the equivalency of a NAND gate is a negative-OR.

### DeMorgan's Second Theorem

DeMorgan's Second theorem proves that when two (or more) input variables are OR'ed and negated, they are equivalent to the AND of the complements of the individual variables. Thus the equivalent of the NOR function and is a negative-AND function proving that and  $\overline{A+B} = \overline{A} \cdot \overline{B}$

again

we can show this using the following truth table.

### Verifying DeMorgan's Second Theorem using Truth Table

Inputs		Truth Table Outputs For Each Term				
B	A	A+B	$\overline{A+B}$	$\overline{A}$	$\overline{B}$	$\overline{A} \cdot \overline{B}$
0	0	0	1	1	1	1
0	1	1	0	0	1	0
1	0	1	0	1	0	0
1	1	1	0	0	0	0

We can also show that  $\overline{A+B} = \overline{A} \cdot \overline{B}$  using logic gates shown.

## DeMorgan's Second Law Implementation using Logic Gates

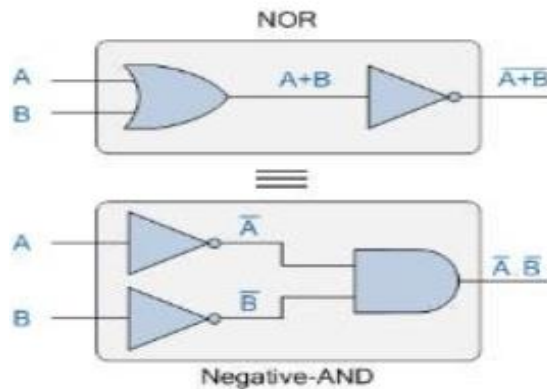

The top logic gate arrangement of:  $\overline{A+B}$  can be implemented using a NOR gate with inputs A and B. The lower logic gate arrangement first inverts the two inputs producing  $\overline{A}$  and  $\overline{B}$ , which become the inputs to the AND gate. Therefore the output from the AND gate becomes:  $\overline{A} \cdot \overline{B}$ .

Thus an AND gate with inverters (NOT gates) on each of its inputs is equivalent to a NOR gate function, and an individual NOR gate can be represented in this way as the equivalency of a NOR gate is a negative-AND.

Although we have used DeMorgan's theorems with only two input variables A and B, they are equally valid for use with three, four or more input variable expressions, for example:

For a 3-variable input

$$\overline{A \cdot B \cdot C} = \overline{A} + \overline{B} + \overline{C}$$

$$\overline{A+B+C} = \overline{A} \cdot \overline{B} \cdot \overline{C}$$

And also

For a 4-variable input

$$\overline{A.B.C.D} = \overline{A} + \overline{B} + \overline{C} + \overline{D}$$

And also

$$\overline{A+B+C+D} = \overline{A}.\overline{B}.\overline{C}.\overline{D}$$

And so on.

### DeMorgan's Equivalent Gates

We have seen here that DeMorgan's Theorems replace all of the AND (.) operators with OR (+) and vice versa and then complements each of the terms or variables in the expression by inverting it, that is 0's to 1's and 1's to 0's before inverting the entire function.

Thus to obtain the DeMorgan equivalent for an AND, NAND, OR or NOR gate, we simply add inverters (NOT-gates) to all inputs and outputs and change an AND symbol to an OR symbol or change an OR symbol to an AND symbol as shown in the following table.

### DeMorgan's Equivalent Gates

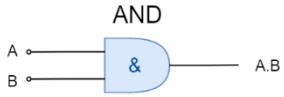
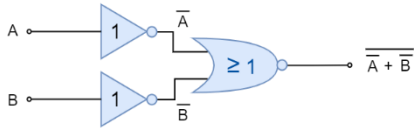
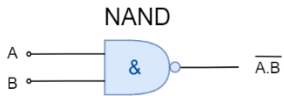
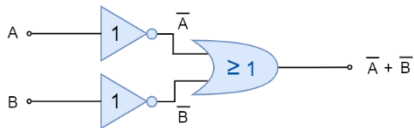
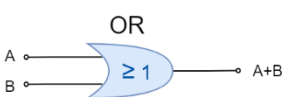
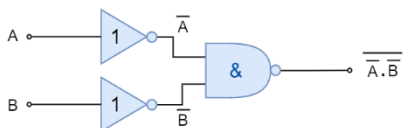
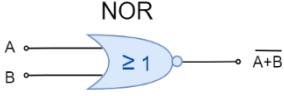
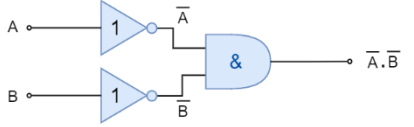
Logic Gate	DeMorgan Equivalent Logic
 <p>AND</p>	<p>Negative - NOR</p> 
 <p>NAND</p>	<p>Negative - OR</p> 
 <p>OR</p>	<p>Negative - NAND</p> 
 <p>NOR</p>	<p>Negative - AND</p> 

Then we have seen that the complement of two (or more) AND'ed input variables is equivalent to the OR of the complements of these variables, and that the complement of two(or more) OR'edvariables is equivalent to the AND of the complements of the variables as defined by DeMorgan

## Experiment-09

**Object:** To design a digital to analog convertor (DAC) by using 3-bit R-2R ladder.

**Apparatus required:** 3- bit R-2R ladder DAC, Connecting wires, Multimeter

**Theory:** A digital-to-analog converter (DAC, D/A, D2A or D-to-A) is a circuit that converts digital data (usually binary) into an analog signal (current or voltage). One important specification of a DAC is its resolution. It can be defined by the numbers of bits or its step size.

The R-2R Digital to Analog Converter uses only two resistance values R and 2R regardless of the number bits of the converter compared to the summing amplifier implementation where each bit resistor has a different value. The circuit shown is a 3 bit DAC.

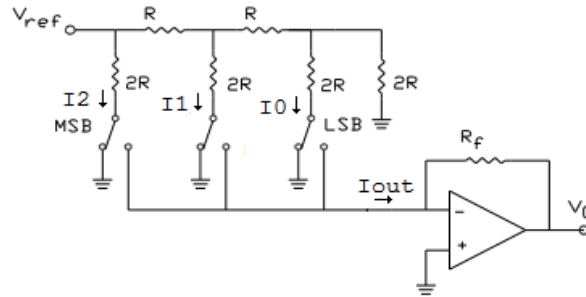

Depending on the state of bit B<sub>2</sub>, B<sub>1</sub> or B<sub>0</sub> , the respective current I<sub>2</sub> , I<sub>1</sub> or I<sub>0</sub> is switched either to ground or to V<sub>-</sub> of the op amp. Thus

$$I_{out} = B_2 I_2 + B_1 I_1 + B_0 I_0 \dots\dots\dots (1)$$

To analysis this circuit, first we observe that since the output is connected to V<sub>-</sub> through R<sub>f</sub>, the op amp is in a negative feedback ( opamp#neg-feedback ), configuration. Thus

$$V_- = V_+ \dots\dots\dots (2)$$

Therefore the individual current values I<sub>2</sub>, I<sub>1</sub>, I<sub>0</sub> are unaffected by the switch setting and the resistor network circuit can be redrawn to the following

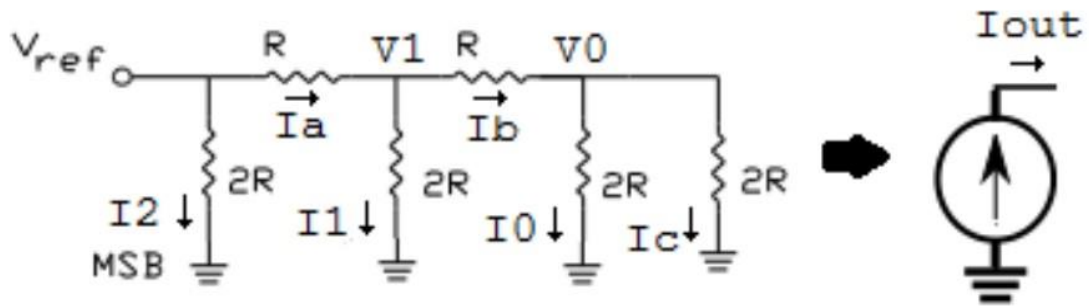

Due to the nature of the resistance network and values , we can obtain the current values by inspection.

From ohms law,

$$I_0 = I_c \dots\dots\dots (3)$$

From KCL at node V0,

$$\begin{aligned} I_b &= I_0 + I_c \\ &= 2I_0 \dots\dots\dots (4) \end{aligned}$$

From KVL,

$$V_1 = I_b R + I_0 2R \dots\dots\dots (5)$$

Substituting equation 4 into equation 6

$$V_1 = 4I_0 R \dots\dots\dots (6)$$

Again applying ohms law to I1 and using equation 6 , we obtain

$$V_1 = I_1 2R = 4I_0 R \dots\dots\dots (7)$$

Or,

$$I_1 = 2I_0 \dots\dots\dots (8)$$

From KCL at node V1 and using equation 4 and 8

$$\begin{aligned} I_a &= I_b + I_1 \\ &= 2I_1 \dots\dots\dots (9) \end{aligned}$$

From KVL ,



$$V_{\text{ref}} = I_4R + I_12R = 4i_1R \dots\dots\dots (10)$$

We leave the reader to figure out how we obtain

$$I_2 = 2I_1 = 4I_0 = V_{\text{ref}}/2R \dots\dots\dots (11)$$

Thus R-2R network can be seen be like a current source whose output depends on switch setting B2,B1,B0 that controls I2,I1,I0 respectively

$$I_{\text{out}} = V_{\text{ref}}(4B_2 + 2B_1 + B_0)/8R \dots\dots\dots (12)$$

Including the op amp which behaves like I-V converter ( current- voltage-converter ), we obtain the voltage output (note the direction of the current source ),

$$V_{\text{out}} = - V_{\text{ref}}R_f(4B_2 + 2B_1 + B_0 )/8R \dots\dots\dots (13)$$

Letting  $V_{\text{ref}} = 1$  and  $R_f = 2R$ , we obtain the following output data

**Output Table**

<b><i>B2</i></b>	<b><i>B1</i></b>	<b><i>B0</i></b>	<b><i>Digital Value</i></b>	<b><i>V<sub>out</sub></i></b>
0	0	0	0	0
0	0	1	1	-0.25
0	1	0	2	-0.5
0	1	1	3	-0.75
1	0	0	4	-1.0
1	0	1	5	-1.25
1	1	0	6	-1.5
1	1	1	7	-1.75

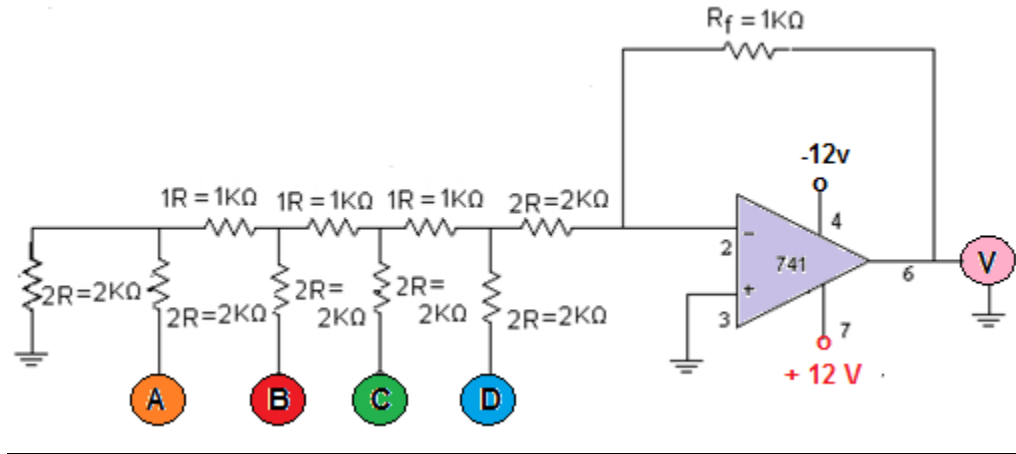

Fig: Practical Circuit of D/A Converter

**Procedure:**

1. Connect to the circuit according to given in the experiment manual.
2. Connect Digital Input Terminals of R-2R Ladder Input with the help of External Input Digit from MSB – LSB / (A-D).
3. Give Digital Input as per the observation table for first combination of Digital Input.
4. Take reading of analog output of D/A Converter by using multimeter in volts.
5. Repeat steps 3 and 4 for other Digital Input Combination of (0-7) Inputs and take note of corresponding outputs in volts

**Results:** When 3-bit digital inputs (from 0 to 7 ) are given to D/A converter, it converts them into analog output signals( analog voltage), that is in linear manner.

**Precautions:**

1. Before perform to the experiment read about D/A ladder type converter.
2. Connect Digital Input according to observation table in linear manner.
3. Prepare or make observation table and circuit diagram in observation notebook before starting the experiment.
4. Switch OFF the experiment kit after the use.