

## EXPERIMENT NO.: 4

### PHASE MODULATION AND DEMODULATION

**AIM:** To study of Phase modulation and demodulation.

#### **APPARATUS :**

1. PM modulation and demodulation kit
2. Dual trace CRO.
3. CRO probes
4. Patch cards.

#### Phase Modulation & Demodulation (PM)

**Definition:** Phase modulation (PM) is a modulation pattern for conditioning communication signals for transmission. It encodes a message signal as variations in the instantaneous phase of a carrier wave. Phase modulation is one of the two principal forms of angle modulation, together with frequency modulation.

In phase modulation, the instantaneous amplitude of the baseband signal modifies the phase of the carrier signal keeping its amplitude and frequency constant. The phase of a carrier signal is modulated to follow the changing signal level (amplitude) of the message signal. The peak amplitude and the frequency of the carrier signal are maintained constant, but as the amplitude of the message signal changes, the phase of the carrier changes correspondingly.

#### **Message signal:**

A message signal contains information or a message. It is the **original signal** that needs to be transmitted from the **transmitter to the receiver**. The transmitter converts the signal into a suitable form and sends it through the communication channel to the receiver. The communication channel is a **medium** for the signal to travel from one end to the other. The receiver perceives the signal, which is converted back to its original form.

A message signal suffers from attenuation and various noise factors. It is essential to modulate the message signal to remove the noise. It also helps in improving the **efficiency** of the signal. Hence, a message signal is often known as a *modulated signal*. Another name of the message signal is the baseband signal.

### Carrier signal:

The carrier signal is the same sinusoidal waveform signal as message signal with greater frequency. It means that the frequency of the carrier signal is higher than the message signal. The Carrier signal is sent with the message signal on the same communication channel during the modulation process. When sent with the message signal, the high-frequency carrier signal increases the frequency of the message signal. It is used in applications where the incoming message signal is low frequency, and the required output signal is high frequency. Phase Modulators:

Modulation refers to converting the information signal to a suitable form of transmission. Here, the incoming message signal is converted to radio waves, which is a suitable mode of transmission for the communication system.

The modulation process of PM is similar to the FM modulation process except for the integrator. FM requires an integrator before the modulated signal is applied to the balanced modulator. The integrator block in FM is present before the balance modulator block. But in PM modulation, no integrator block is required. The block diagram of the PM modulator is shown below:

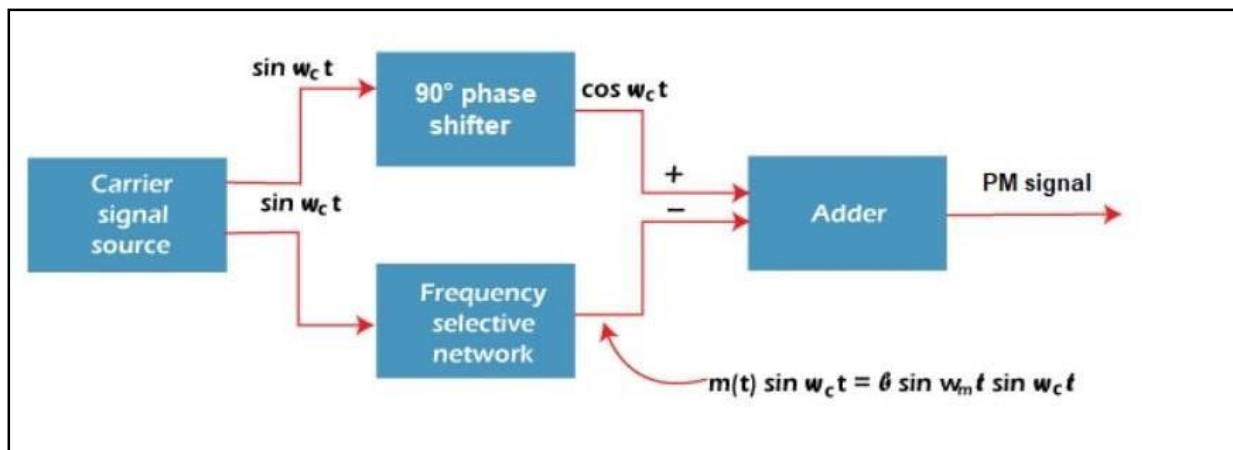

The circuit consists of a **carrier signal source**, **balance modulator**, **adder**, and a **90-degree phase shifter**. The carrier signal source generates a carrier  $\sin \omega_c t$  with the carrier frequency  $\omega_c$ . The 90-degree phase shifter converts the carrier signal  $\sin \omega_c t$  to  $\cos \omega_c t$ , which is the carrier with a phase shift of  $90^\circ$ . A balance modulator generates a double sideband amplitude modulated signal by superimposing the message and the carrier signal  $\sin \omega_c t$ . The output signal is generally a suppressed carrier signal. The output of the balance modulator and

the output of the phase shifter are sent to the adder, which adds these two outputs. The carrier shifted by a phase of  $90^\circ$  when added to the output of the balanced modulator forms a phase-modulated signal.

We can also use a frequency modulator as a phase modulator by passing the FM signal through a differentiator and an FM modulator.

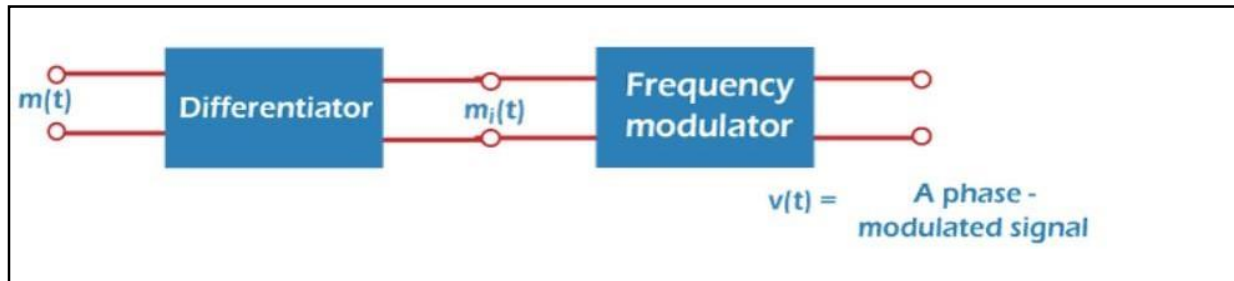

Where,  $m(t)$  is the modulated signal

$m_i(t)$  is the instantaneous modulated signal, which is the output of the differentiator.

$v(t)$  is the phase modulated signal, output of the frequency modulator.

### **Graphical Representation of Phase Modulated Wave:**

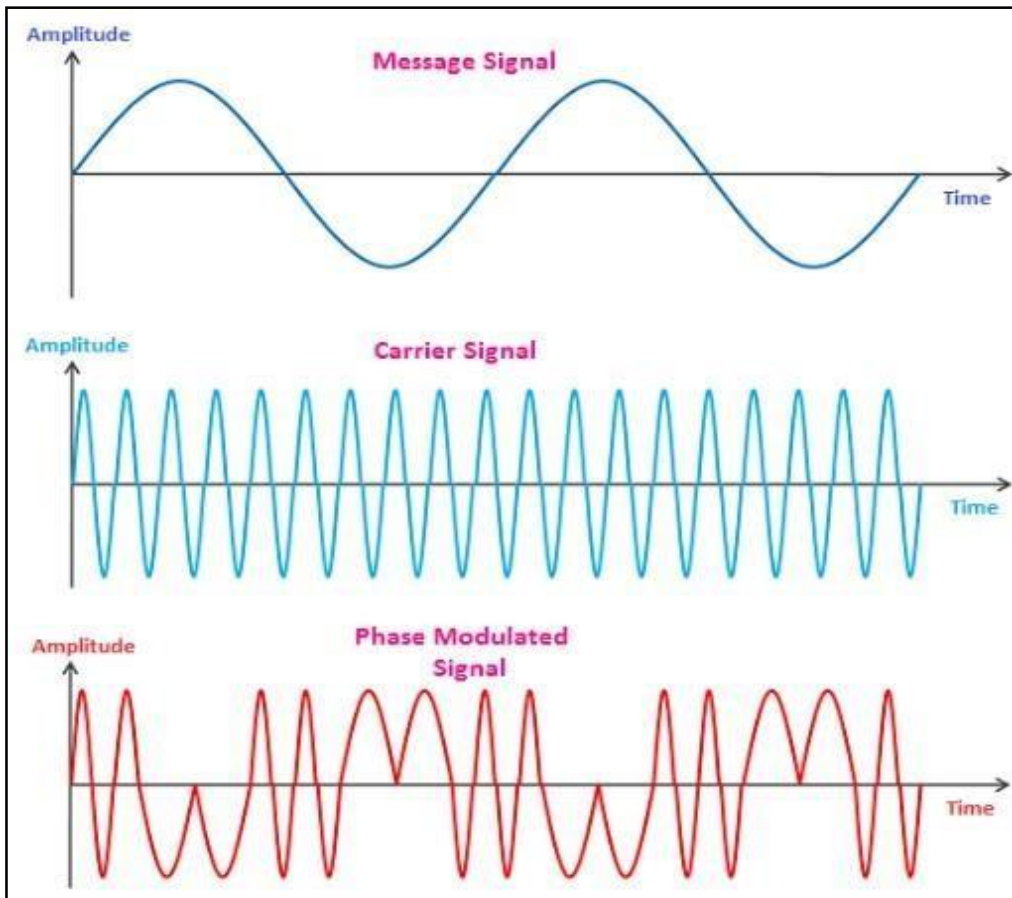

Fig. The output of Phase Modulation.

### **QUESTIONS**

1. Define FM & PM.
2. What are the advantages of Angle modulation over amplitude modulation?
3. What is the relationship between PM and FM?
4. With a neat block diagram explain how PM is generated using FM.