

GURU GHASIDAS VISHWAVIDYALAYA, BILASPUR

DEPARTMENT OF INDUSTRIAL AND PRODUCTION
ENGINEERING



Session (2020-2021)

SEMINAR PROJECT ON AUTOCAD

Roll no. - 18105002

Enroll. no.- GGV/18/1025

Submitted to:
Kailash Borkar sir

Submitted by:
Akhilesh Tirkey

DECLARATION

I hereby certify that the work which is being presented in the report entitled “AUTODESK AUTOCAD” in fulfilment of the requirement for completion of one month industrial training in department of Industrial and Production engineering of “Guru Ghasidas Vishwavidyalaya” is an authentic record of my own work carried out during industrial training.

AKHILESH TIRKEY

ACKNOWLEDGEMENT

I am highly grateful to **Mrs. Arpita Roy Choudhury, HOD (IPE Department)** for providing this opportunity to carry out one month practical training at **INTERNSHALA**.

The constant guidance and encouragement received from **Mr. Kailash Borkar, Assistant Professor (IPE Department)** has been of great help in carrying out the project work and is acknowledged with reverential thanks.

I would like to express a deep sense of gratitude and thanks profusely to **Mr. Tushar Jha, Instructor** , without the wise counsel and able guidance, it would have been impossible to complete the report in this manner

I would like to express gratitude to other faculty members of IPE department for their intellectual support throughout the course of this work.

Finally, I am indebted to all whosever have contributed in this report.

CERTIFICATION

INTERNSHALA TRAININGS

Certificate of Training

Akhilesh Tirkey

from **Guru Ghasidas Vishwavidyalaya** has successfully completed a six weeks online training on **AutoCAD** from 18th June, 2020 to 30th July, 2020. The training consisted of Interface, Drawing Aids & Basic Objects, Complex Objects & Object editing, Blocks & Annotations and Plotting & Introduction to 3D modules. Akhilesh scored 95% marks in the final assessment and is a top performer in the training. We wish Akhilesh all the best for the future.

Sarvesh Agrawal
Founder & CEO, Internshala

Date of certification: 2020-07-12

Certificate no. : 04FB62F5-5619-86EC-F8AD-93D9A69F761F

For certificate authentication, please visit https://trainings.internshala.com/verify_certificate

CONTENTS

SR. NO.	PARTICULARS	PAGE NO.
1	CHAPTER-1 AUTOCAD	
2	1. INTRODUCTION	5-6
3	2. AUTOCAD WINDOW	6-17
4	3. SELECTING THE WORKSPACE	17
5	4. FILLING THE DATA INPUT	17-20
6	COORDINATES ENTRY	20-22
7	NAVIGATION TOOL OBJECT DISPLAY	22-25
8	DRAWING UNITS AND LIMITS	25-27
9	COMMANDS	27-36
10	DIMENSION TOOLBAR	36-41
11	TEXT COMMAND	41-42
12	TABLE	42-43
13	LAYER	44-45
14	ISOMETRIC DRAWING	45-46
15	3D MODELING	47-53
16	PRINTING AND PLOTTING	53-54
17	CONCLUSION	55

CHAPTER -1

AUTOCAD



1. INTRODUCTION

AutoCAD is a commercial software application for 2D and 3D computer-aided design (CAD) and drafting — available since 1982 as a desktop application and since 2010 as a mobile web- and cloud-based app marketed as AutoCAD 360.

Developed and marketed by Autodesk, Inc., AutoCAD was first released in December 1982, running on microcomputers with internal graphics controllers. Prior to the introduction of AutoCAD, most commercial CAD programs ran on main-frame computers or minicomputers, with each CAD operator (user) working at a separate graphics terminal. AutoCAD is used across a wide range of industries, by architects, project managers, engineers, graphic designers, and other professionals. It is supported by 750 training centers worldwide as of 1994.

As Autodesk's flagship product, by March 1986 AutoCAD had become the most ubiquitous CAD program worldwide. As of 2014, AutoCAD is in its twenty-ninth generation, and collectively with all its variants, continues to be the most widely used CAD program throughout most of the world.

The latest version was released on 23th march 2021 as AutoCAD 2022.

2. AUTOCAD WINDOW

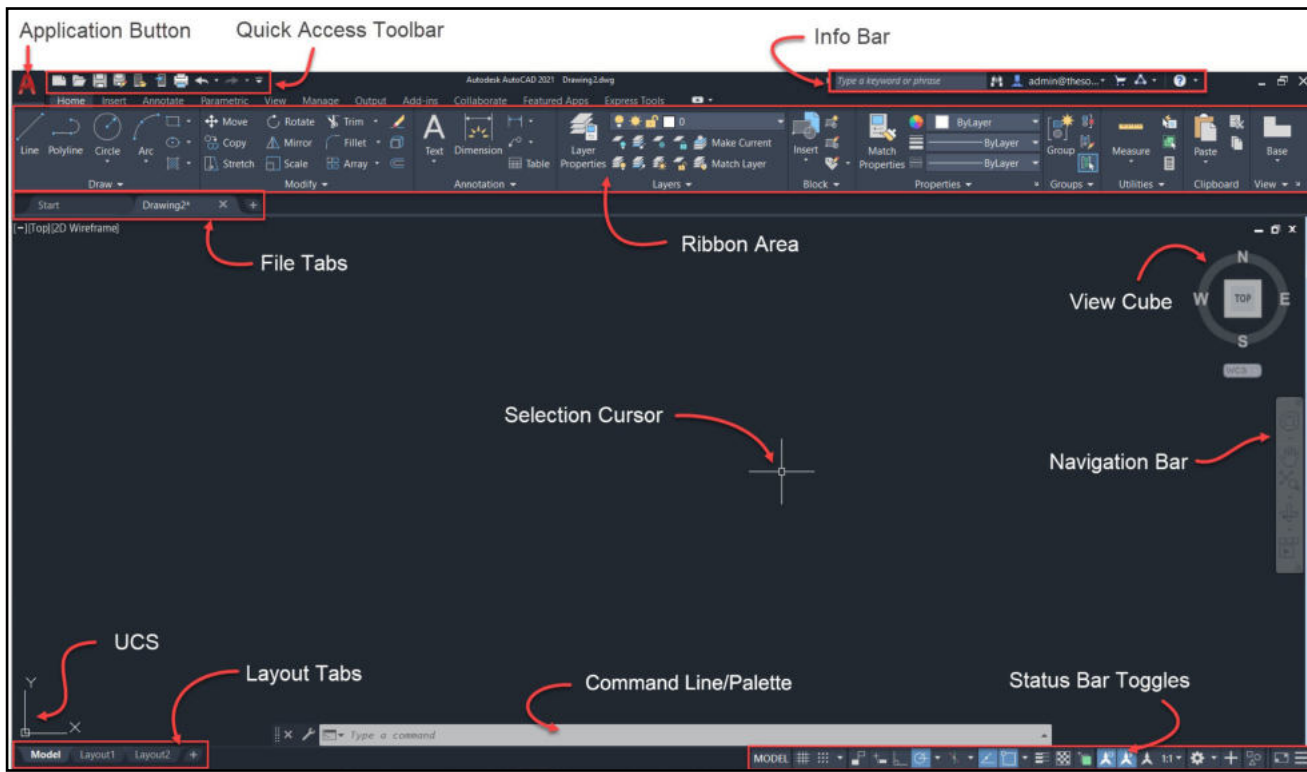

Once the AutoCAD 2021 window is active, it should appear as shown below. However, if you look at the upper left-hand corner, there is a button with the letter (A) written in red. This is called the application menu of the AutoCAD software. At the right of this button, there is the phrase "3D modeling". This means that the active workspace is modeling.

1. Application button

This provides the user with file options like, save, open, print.

2. Quick Access toolbar

Display frequently used tools with the Quick Access toolbar.



View Undo and Redo History

As with most programs, the Quick Access toolbar displays options to undo and redo changes to your work. To undo or redo a less recent change, click the drop-down button to the right of either the Undo or the Redo button.



Add Commands and Controls

You can easily add commonly used tools to the Quick Access toolbar by clicking the indicated drop-down button and clicking your choices from the drop-down menu.



Tip: For a fast way to add a ribbon button to the Quick Access toolbar, right-click any button on the ribbon, and then click Add to Quick Access Toolbar.

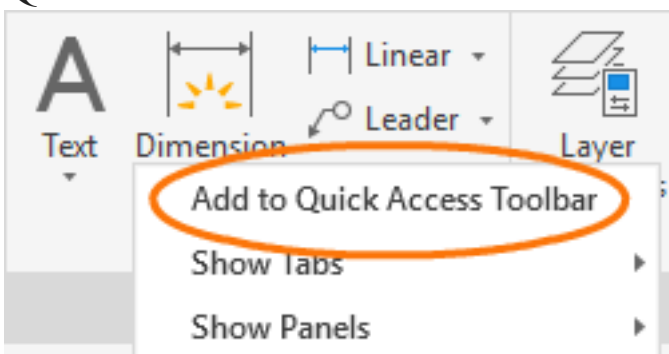

Buttons are added to the right of the default commands on the Quick Access toolbar. To remove one of these commands, use the CUI editor and open the [+] Quick Access Toolbars > [+] Quick Access Toolbar 1. From there, you can click and press Delete. You can also drag the elements to change their order on the toolbar.

3. Ribbon

The ribbon organises tools into logical groupings.

The ribbon provides a compact palette of all of the tools necessary to create or modify your drawing. It can be placed in the following places:

- Docked horizontally at the top of the drawing area (default)
- Docked vertically along the right or left edge of the drawing area
- Undocked, or floating within the drawing area or on a second monitor

Ribbon Tabs and Panels

The ribbon is composed of a series of tabs, which are organized into panels that contain many of the tools and controls available in toolbars.

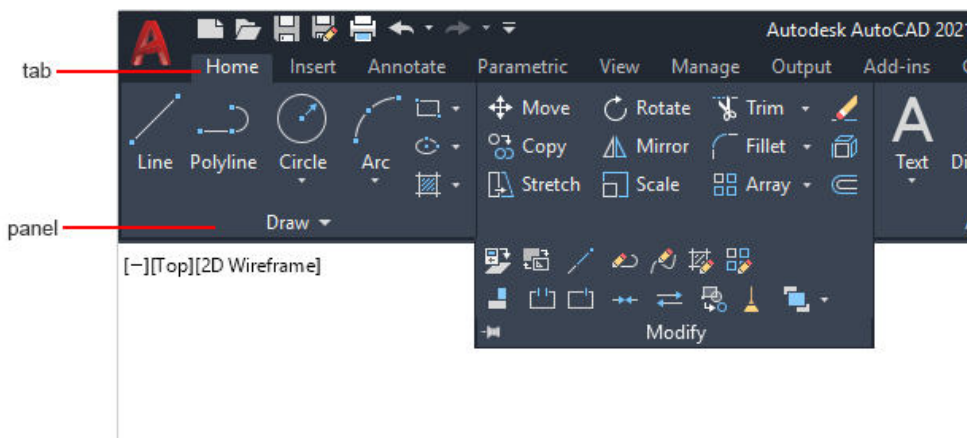

Some ribbon panels provide access to a dialog box related to that panel. To display the related dialog box, click the dialog box launcher is denoted by an arrow icon, , in the lower-right corner of the panel.

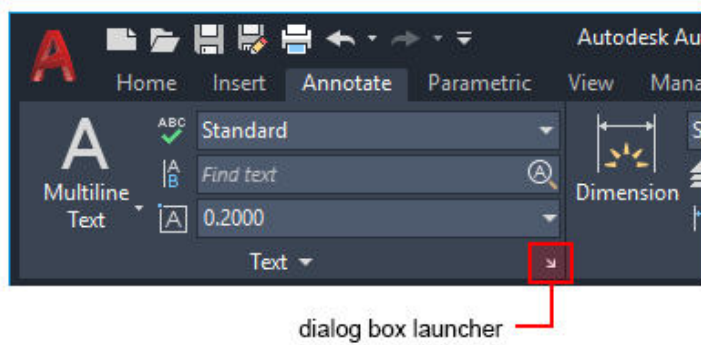



Note: You can control which ribbon tabs and panels are displayed. Right-click the ribbon and click or clear the names of tabs or panels listed on the shortcut menu.

Floating Panels

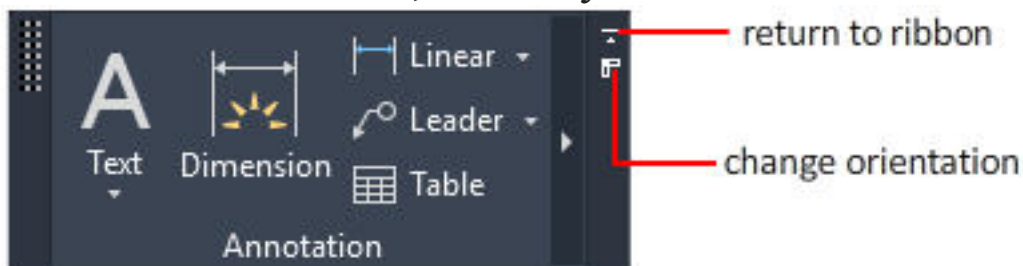
You can pull a panel off a ribbon tab and into the drawing area or onto another monitor. The floating panel remains open until you return it to the ribbon, even if you switch ribbon tabs.



Slide-out Panels

If you click the arrow in the middle of a panel title, , the panel will expand to display additional tools and controls. By default, slide-out panels automatically close when you click another panel. To keep a panel expanded, click the push pin, , in the bottom left corner of the slide-out panel.

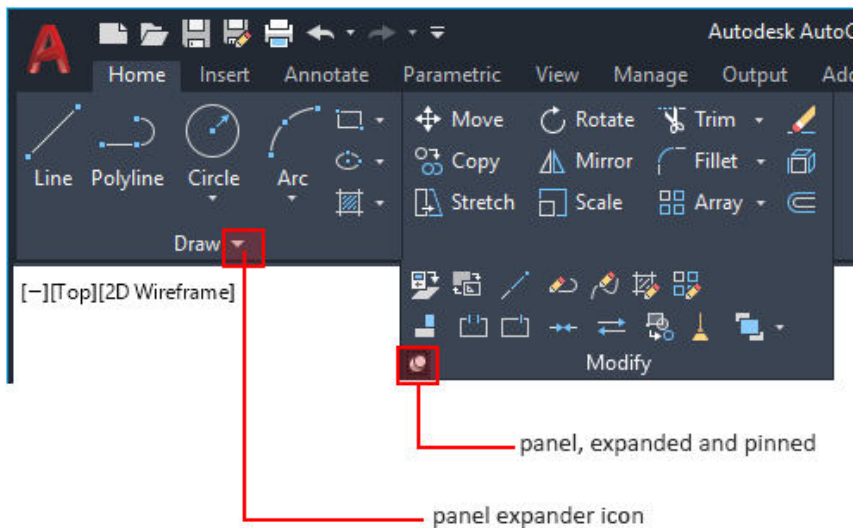

Contextual Ribbon Tabs

When you select a certain type of object or start certain commands, a contextual ribbon tab is displayed instead of a toolbar or dialog box. The contextual tab closes when you end the command.

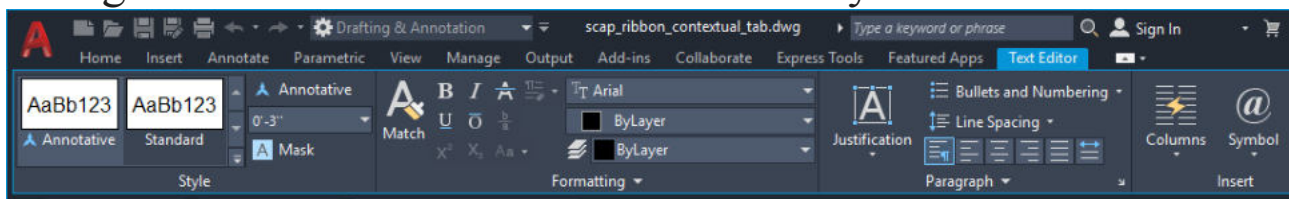

Workspaces and the Ribbon

For products that run on the Windows operating system, a workspace is set of ribbon tabs and panels, menus, toolbars, and palettes that provide you with a custom, task-oriented drawing environment. You can change to a different the ribbon by changing the workspace. On the status bar, click Workspace Switching and select the workspace you want to use. For example, here are the initial workspaces available in AutoCAD.

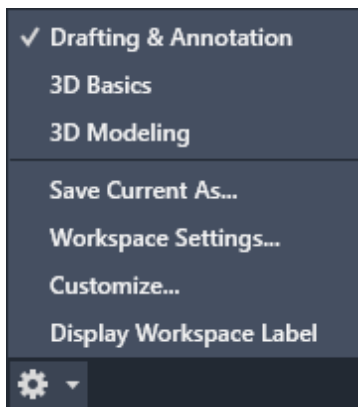

4. File Tabs

Displays the file tabs at the top of the drawing area.



Find

File tabs provide an easy way for you to access all the open drawings in the application. The file tab usually displays the full name of the file. Clicking the plus sign (+) on the right end of the file tabs bar opens a new drawing based on the specified template file used by the QNEW command.

Note: If there is no specified template, clicking the plus sign (+) opens a new drawing based on the last used template.

Drag a drawing from Windows Explorer or File Explorer into any part of the file tab bar to open it.

Use Ctrl+TAB to navigate through the file tabs.



You can right-click on the file tabs or the file tab bar to access the shortcut menus that offer you options to open, close or save drawings.

5. Status bar

The status bar displays the cursor location, drawing tools, and tools that affect your drawing environment.

The status bar provides quick access to some of the most commonly used drawing tools. You can toggle settings such as grid, snap, polar tracking, and object snap. You can also access additional settings for some of these tools by clicking their drop down arrows.

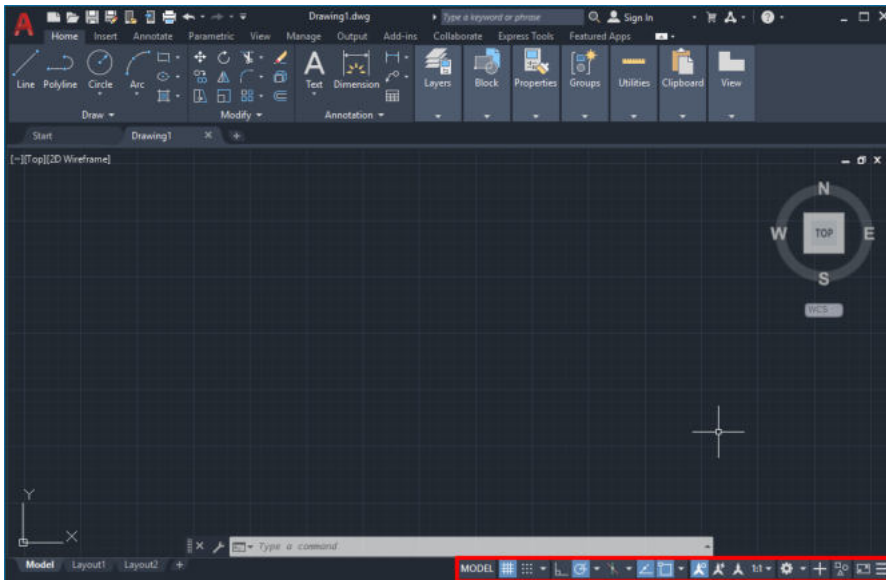

Note: Not all tools are displayed by default; you can choose what tools to display from the Customization menu, the right-most button on the status bar. The tools displayed on the status bar might change depending on the current workspace and whether the Model tab or a layout tab is currently displayed.

You can also toggle some of these settings with the function keys on your keyboard (F1 - F12).

6.View Cube

The ViewCube is a 3D navigation tool that appears when the 3D graphics system is enabled and allows you to switch between standard and isometric views.

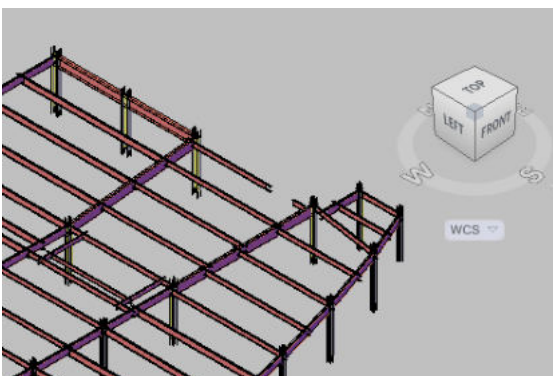

Once the ViewCube is displayed, it displays in one of the corners of the drawing window over the model in an inactive state. When you position the cursor over the ViewCube, it becomes active. You can switch to one of the available preset views, roll the current view, or change to the Home view of the model.

ViewCube is also displayed in the Object Viewers. The ViewCube is always turned on in Object Viewers.

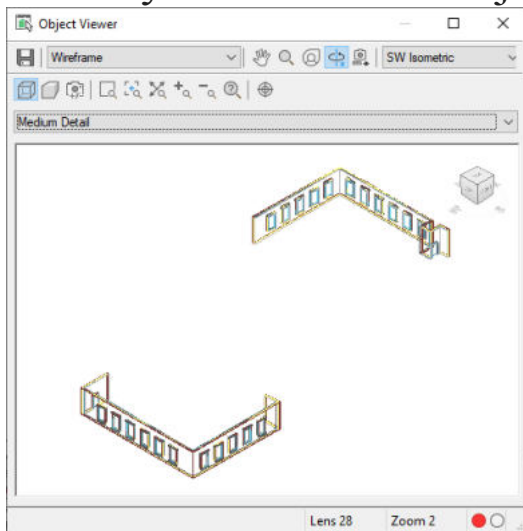

Note:

- The View Cube is visible by default. An exception to this are the 2D Wireframe and 3D Hidden visual styles, where View Cube is not displayed.
- When ViewCube is displayed in the drawing area, you have access to a compass and can define a UCS. In an Object Viewer, no UCS option and no compass are available.

7. Navigation bar

The navigation bar is a user interface element where you can access both unified and product-specific navigation tools.

Unified navigation tools are those that can be found across many Autodesk products. Product-specific navigation tools are unique to a product. The navigation bar floats over and along one of the side of the drawing window.

Start navigation tools by clicking one of the buttons on the navigation bar or selecting one of the tools from a list that is displayed when you click the smaller portion of a split button.



The following unified navigation tools are available from the navigation bar:

- **SteeringWheels.** The 2D SteeringWheel provides rapid switching between specialized navigation tools.
- **3D connexion.** Set of navigation tools used to reorient the current view of a model with a 3D connexion 3D mouse.

The following product-specific navigation tools are available from the navigation bar:

- **Pan.** Moves the view parallel to the screen.
- **Zoom tools.** Set of navigation tools for increasing or decreasing the magnification of the current view of a model.

Use the Navigation Bar in Paper Space



In paper space, only the 2D navigation tools (such as 2D SteeringWheel, Pan, Zoom, and the 2D Mode 3D connexion tools) are accessible.

Repositioning the Navigation Bar

Drag the grip handle on the navigation bar to reposition it along one of the sides of the current window

If the side of the window that the navigation bar is aligned to is not long enough to show the entire navigation bar, it is truncated to fit. When truncated, a More Controls button is displayed and replaces the Customize button. When you click the More Controls button, a menu is displayed that contains the navigation tools that are not currently being displayed.

8. UCS

Sets the origin and orientation of the current user coordinate system (UCS).



Find

The UCS is a moveable Cartesian coordinate system that establishes the *XY* work plane, horizontal and vertical directions, axes of rotation, and other useful geometric references. You can change the UCS origin and orientation for convenience as you specify points, enter coordinates, and work with drawing aids, such as Ortho mode and the grid.

A UCS can be stored with a viewport if the UCSVP system variable is set to 1 for that viewport.

Note: By default, the Coordinates panel is hidden in the Drafting & Annotation workspace. To display the Coordinates panel, click the View tab, then right-click and choose Show Panels, and then click Coordinates. In 3D workspaces (not available in AutoCAD LT), the Coordinates panel is on the Home tab.

9. Layout tab

A layout is a 2D working environment for creating drawing sheets. The area within a layout is called *paper space*, where you can add a title block, display scaled views of model space within *layout viewports*, and create tables, schedules, notes, and dimensions for your drawing.

You can access one or more layouts from the tabs located at the bottom-left corner of the drawing area to the right of the Model tab. You can use multiple layout tabs to display details of the various components of your model at several scales and on different sheet sizes.

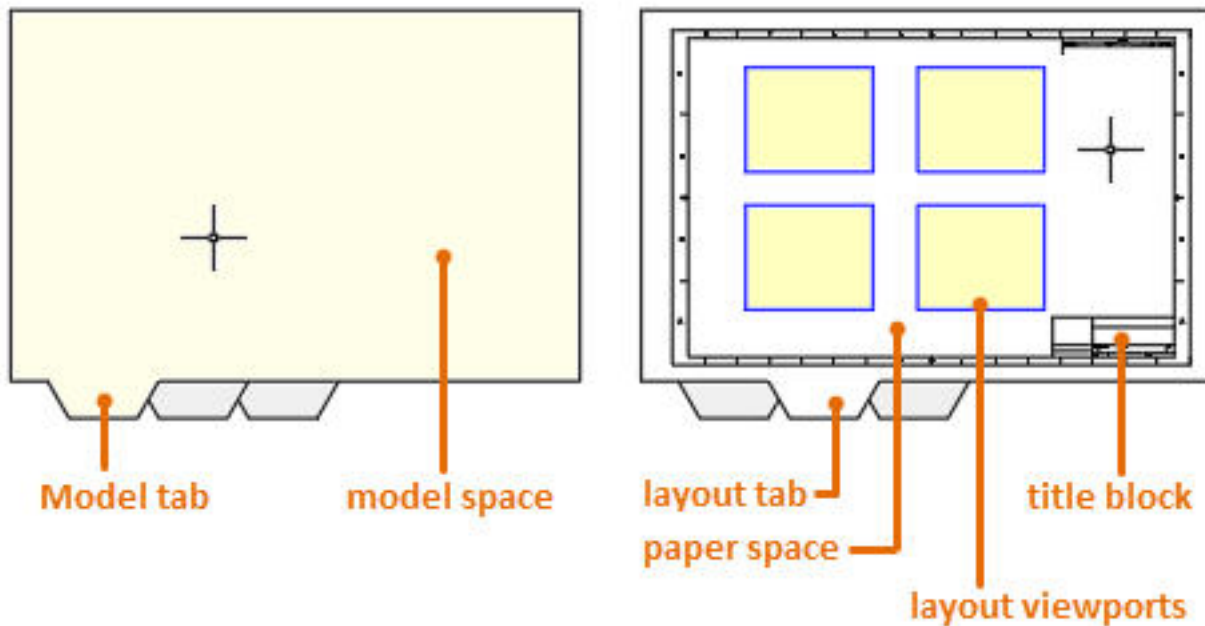

There are several ways in which you can add new layouts or copy existing layouts.

- Use the LAYOUT command
- Right-click a layout tab
- Step through the Create Layout wizard
- Use Design Center

Each layout stores its own *page setup* which controls the appearance and format for displaying and printing each layout. For example, you would use the page setup to specify the sheet size and orientation. The Page Setup Manager is accessible from the PAGE SETUP command, the Application menu, and the ribbon.

10. Command line/palette

Displays the Command window.



Find

The Command window accepts command and system variable input and displays prompts that guide you through the command sequence.

You can also press Ctrl+9 to toggle the display of the command window.

3. SELECTING THE WORKPIECE

A workspace is a task oriented drawing environment oriented in such a way as to provide you with only the tools and interface elements necessary to accomplish the task relevant to that environment . you can switch between workspace by using the workspace switching tool. You can also customize the workspace the way you want and then save it.It will be appearing on the list of workspace during switching and you can select it as an option.

workspace switching tool takes the form of a gear wheel located at the bottom right hand corner of the active window. clicking on it produces a drop down list of other alternative workspaces. clicking on either changes the workspace to the selected choice. Alternatively you can switch the workspace by clicking on the downward arrow besides the name of the current workspace on the quick access toolbar.

4. FILING AND DATA INPUT

AutoCAD 2014 file operations are similar to the file operations in any other Windows program. The general file handling commands include file saving, file opening, file closing and printing of drawings.

I. OPENING FILES

There are three ways to open a drawing in AutoCAD.

○ Using Application Menu

- Click on Application Menu > Open
- On the select file dialogue box that appears, browse through the folders in the Look in slot. This enables you to navigate to the folder where you've saved your drawing.
- Clicking on a file allows you to look at a preview of the drawing.
- Select OPEN.

○ Using the Quick Access Toolbar

- Click on File pull down menu > Open
- At the Select file dialogue box, browse through to the folder in the Look in slot.
- Clicking on a file allows you to look at a preview of the drawing.
- Now you can click Open in the select file dialogue box.

○ Using the command line

- At the command prompt on the command line, type Open and enter.

- At the Select file dialogue box, browse through to the folder in the Look in slot.
- Clicking on a file allows you to look at a preview of the drawing.
- Select OPEN.

II. FILE SAVING

○ To save a drawing for the first time

The Save Drawing dialogue box appears when you are saving a drawing for the first time. You are required to navigate through the folders in the save in slot to select the folder in which you want to save your drawing. Type in the file name and then click save.

If you modify a drawing you may wish to save it again but retaining the original template. In this case select save as from the file pull down or the application menu. Give it a name that signifies its current status i.e. taking into account the changes. Click save.

○ Saving a File as You Work

It's a good idea to save your file periodically as you work on it. As with any Windows program, you can save it under its original name by click on the Save tool on the Quick Access toolbar or under a different name by choosing Save As from the Application menu, thereby creating a new file.

○ Making Changes

Coming up with certain drawings may not take place in one pass.

Some will require modifications at virtually every stage. Others involve a series of iterative stages before settling on the final copy. In these circumstances, AutoCAD offers the required flexibility as opposed to manual drawing. To keep track of all the modifications, the Save As tool is very essential.

III. CLOSING A FILE

Simply click on the X button on the top right corner of the AutoCAD window to close a drawing. A dialogue box appears asking whether to save the changes on the drawing. Select yes to save the changes and no if you don't want to effect the changes. However it's usually a good practice to save your files before closing them.

5. COORDINATES ENTRY

1. OVERVIEW.

When a command prompts you for a point, you can use the mouse to specify a point, or you can enter a coordinate value at the command prompt. If the dynamic input is switched you can enter coordinate values in tooltips near the cursor.

Two-dimensional coordinates can be entered as either Cartesian (X, Y) or Polar coordinates.

I. CartesianCoordinateSystem

A Cartesian coordinate system has three axes, X, Y, and Z. when you enter coordinate values, you indicate a point's distance in units and its direction (+ or -) along the X, Y, and Z axes relative to the coordinate system origin (0,0,0).

In 2D, you specify points on the XY plane, also called the work plane. The X value of Cartesian coordinate specifies the horizontal distance, and the Y value specifies the vertical distance. The origin point (0, 0) indicates where the two axes meet.

II. Polar Coordinate System

Polar coordinates use a distance and an angle to locate a point.

III. Absolute and Relative Coordinates

1. Absolute coordinates

Represents a specific point in the current work plane relative to the origin point (0,0). To enter an absolute coordinate, type the values as a Cartesian coordinate (X,Y) or Polar coordinate (distance, angle).

2. Relative coordinate

A relative coordinate is a point specified with reference to the last point specified. We emphasize that it is with reference to your last specified point and not to the origin. This is the distinguishing aspect between relative and absolute coordinates.

3. Dynamic Input

When dynamic input is on, tooltips display information near the cursor as it moves. It is called dynamic input because the information moving with the cursor is updated with the motion of the cursor. If you type the X value and press tab, the X field (box) displays a lock icon, The Y field is active and you can enter its value. If you type the X value and press enter, the Y value is ignored and AutoCAD interprets it as direct distance entry. This procedure applies to any other set of fields for instance distance and angle.

6. NAVIGATION TOOLS OBJECT DISPLAY

I. Overview

When drawing in both 2D and 3D, you may wish to:

- a. Get a closer look (magnify your drawing).

- b. View hidden details
- c. Bring the whole drawing into focus.
- d. View the hidden details of your 3D drawing.

For a, b and c use the zoom and pan tools as follows:

i. Zoom in to magnify and zoom out to minimize the size. Zooming out enables you

to see the details that are currently spilt out of the screen or make the object smaller in readiness to add details.

ii. The pan tool allows you to drag your drawing to a convenient location on the screen.

iii. For d use the orbit tool. It is the tool that enables you to view the objects in your drawing from different angles. It is very essential, when drawing in 3D.

II. Accessing the tools

A. Zoom

a. To zoom a view with a single click.

- i. Display a wheel.
- ii. Right-click the wheel and click Steering Wheel Settings.
- iii. In the Steering Wheels Settings dialog box, under Zoom Tool, select Enable Single Click Incremental Zoom.
- iv. Click OK.

- v. Display one of the Full Navigation Wheels or the mini View Object Wheel.
- vi. Click the Zoom wedge. The magnification of the model is increased and you are zoomed in closer to the model. If you hold down the Shift key while clicking the Zoom wedge, the model is zoomed out or you can hold down the Ctrl key to zoom in.
- vii. Click Close to exit the wheel.

b. To zoom a view in and out by dragging.

- i. Display the 2D Navigation wheel, one of the Full Navigation wheels, or the mini View Object wheel.
- ii. Click and hold down the Zoom wedge. The cursor changes to the Zoom cursor.
- iii. Drag vertically to zoom in or out.
- iv. Release the button on your mouse to return to the wheel.

NB: The mouse wheel is a very convenient way of zooming in and out.

B. Pan

a. To pan the drawing with the pan tool.

- i. Display the 2D Navigation wheel, one of the Full Navigation wheels, or the mini View Object wheel.
- ii. Click and hold the Pan wedge. The cursor changes to the Pan cursor.

- iii. Drag to reposition the model.
- iv. Release the button on your pointing device to return to the wheel.

b. To pan using the middle mouse button or the mouse wheel.

- i. Press and hold down the scroll wheel or middle button. The cursor changes to the Pan cursor.
- ii. Drag to reposition the model.
- iii. Release the wheel or button on your mouse.

C. Orbit

- i. Display one of the View Object or Full Navigation wheels.
- ii. Click and hold down the Orbit wedge. The cursor changes to the Orbit cursor.
- iii. Drag to rotate the model.
- iv. Release the button on your mouse.

B: To navigate to the zoom, pan or orbit tools, go to:

- a. View tab> navigate panel> zoom or
- b. View tab> navigate panel> pan or

c. View tab> navigate panel> orbit.

7. DRAWING UNITS & LIMITS

• UNITS

The format, precision, and other settings used to display coordinates, distances, and angles are set through this dialog box, and are saved in the current drawing. It is recommended that you save these settings to your drawing template files to reduce your setup time when you start a new drawing. The Drawing Units dialog box is displayed. Enter -units at the Command prompt to display options.

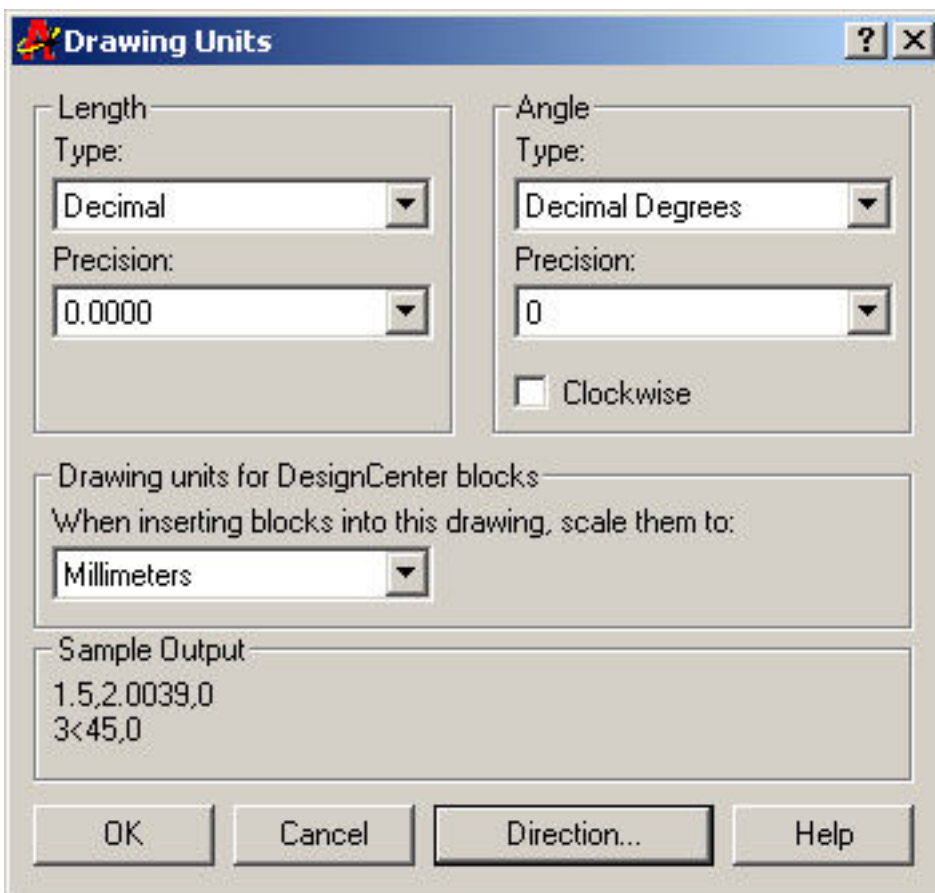

- Limits:

When you start a new drawing, and then decide how much space I need for my drawing. Think of it as the size of your drawing area. Then you can define drawing limits correctly. Type LIMITS enter. Type 0,0 as lower left corner then type or click the coordinate for upper right corner based on the units which is in Inches or mm.

- Command: LIMITS

Reset Model space limits:

Specify lower left corner or [ON/OFF] <0.0000, 0.0000>: 0, 0

Specify upper right corner <100.0000, 100.0000>: 300,200

8. COMMANDS

1. OVERVIEW AND DEFINITIONS.

You communicate with AutoCAD by using tools and Menu options. These devices invoke AutoCAD commands.

I. What is a command?

It's a single-word instruction you give to AutoCAD telling it to do something such as draw a line (the line tool in the Draw Ribbon Panel) or erase an object (the Erase tool in the Modify Ribbon Panel). Whenever you invoke a command, by either typing it or selecting a menu option or tool, AutoCAD responds by presenting messages to you in the Command Window and the Dynamic Input display or by displaying a dialogue box. By right clicking during the drawing process, a context-sensitive short cut menu is displayed; i.e. if you are in the middle of a command, this menu displays a list of options specifically related to that command.

II. Command tools.

Move the arrow cursor to the Line tool and rest it there. Do not click yet. Hold it there for a little while and then for a longer

while. You will see two tool tips. The first tip gives you the tool tip name and the keyboard command associated with the tool. The second tip gives a brief explanation of how to use the tool. This happens to all other tools on the ribbon. To be able to draw effectively with AutoCAD, you must learn how to tell AutoCAD what you want, and even more important, understand what AutoCAD wants from you.

III. Methods of Accessing/Activating Commands.

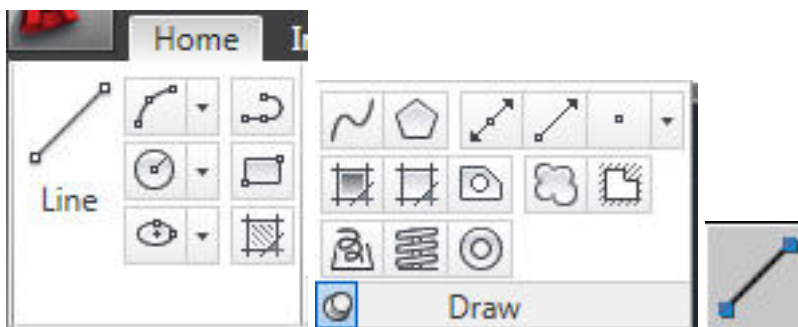

1. Clicking on the command tool/icon on the Ribbon Panels.
2. Typing the command on the Keyboard.
3. Use of Accelerator Keys. These are special keystrokes that open and activate drop down menu options. Example is Ctrl+S for save and Ctrl+C for copy.
4. Use of Aliases; (one, two or three letter abbreviations of a command name).
These are also typed on the key board.

2. Draw Command Tools

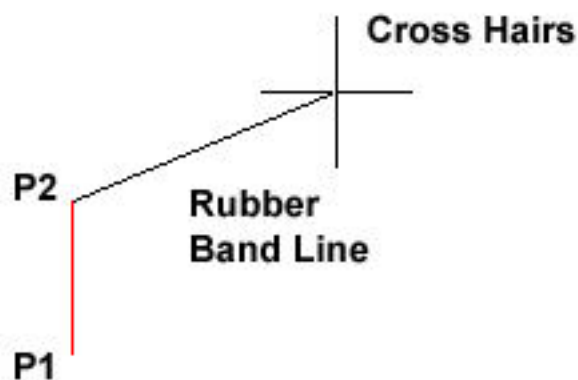

1.  **Line:** With the Line command you can draw a simple line from one point to another.



2.  **Construction line:** The construction line command creates a line of infinite length which passes through two picked points.
3.  **Polyline :** The Polyline command is similar to the line command except that the resulting object may be composed of a number of segments which form a single object.
4.  **Rectangular :** The Rectangle command is used to draw a rectangle whose sides are vertical and horizontal. The position and size of the rectangle are defined by picking two diagonal corners.
5. **Polygon:** The polygon command can be used to draw any regular polygon from 3 sides up to 1024 sides. This command requires four inputs from the user, the number of sides, pick point for the centre of the polygon, whether you want polygon inscribed or circumscribed and then a pick point which determines both the radius of this imaginary circle and the orientation of the polygon. The polygon command creates a closed poly line in the shape of the required polygon.
6. **Circle:** The Circle command is used to draw circles. There are a number of ways you can define the circle. The default method is to pick the centre point and then to either pick a second point on the circumference of the circle or enter the circle radius at the keyboard.

7.Arc:The Arc command allows you to draw an arc of a circle. There are numerous ways to define an arc; the default method uses three pick points, a start point, a second point and an end point.

8.Spline : A spline is a smooth curve that is along a number of control points. the fit Tolerance option can be used to control how closely the spline conforms to the control points. A low tolerance value causes the spline to form close to the control points.

9. Ellipse: The Ellipse command gives you a number of different creation options. The default option is to pick the two end points of an axis and then a third point to define the eccentricity of the ellipse.

10. Hatch: Hatch is used to add shaded patterns to objects and shapes. You can pick: Pattern, Scale, Angle, Points

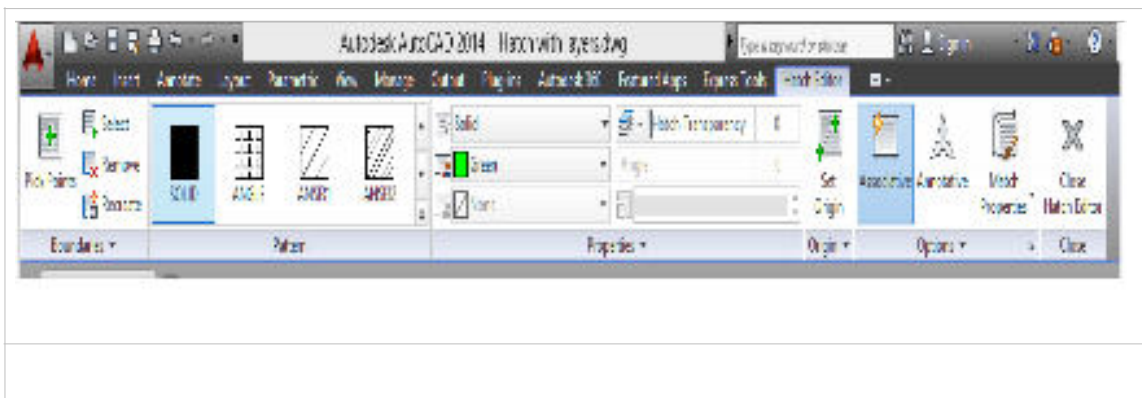

3.MODIFY COMMANDS

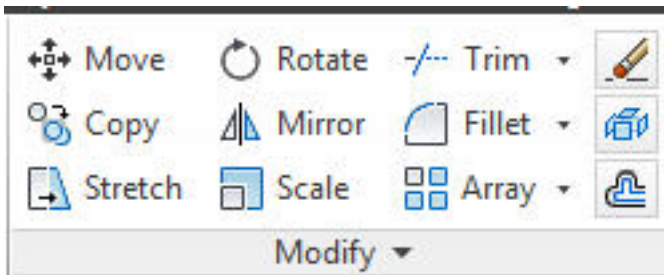

- **Offset:** Create a duplicate object parallel with the original object. If this object is a Polyline or a Circle, the duplicate shape will be transformed inwards or outwards.
-
- **Copy:** Copy's one or more objects .
-
- **Mirror:** Create a mirror image of an object. It is useful for creating symmetrical objects because you can quickly draw half the object and then mirror it instead of drawing the entire object
- **Array:** Create copies of objects in a rectangular or polar pattern. This is especially useful when you need to duplicate several objects at the same distance from each other. **For rectangular arrays,** you control the number of rows and Columns and the distance between each. **For polar arrays,** you control the number of copies of the object and whether the copies are rotated.
- **Move:** Moves one or more objects.
- **Rotate:** You can rotate objects with an absolute or relative angle. When using an absolute angle: Specify the base point and then specify the rotation angle.

- **Scale:** A scale factor greater than 1 enlarges the object. It is also possible to scale an object using a reference object. This method scales the object equally in all directions.
- **Trim:** With the trim option objects can be shortened or lengthened with the edges of other objects. Objects can exactly be fitted between these objects.
- **Extend:** With the extend option you can shorten or lengthen objects to meet the edges of other objects. For example a line can be exactly fitted between objects. Extending an object works in the same way as trimming.
- **Fillet:** You can use the fillet tool to connect two objects with an arc with a specified radius. The inside corner is called a fillet and an outside corner is called a round.
- **Chamfer** is almost identical to fillet, but it will make a straight line instead of an arc
- **Join:** You can use the join option to combine similar objects into one single object. It is also possible to create complete circles from arcs.
- **Explode:** Polylines, hatches or blocks can be converted into individual elements with the explode option. If you explode a polyline every segment will become a separate line.

Some Drawings using Draw and Modify Toolbars

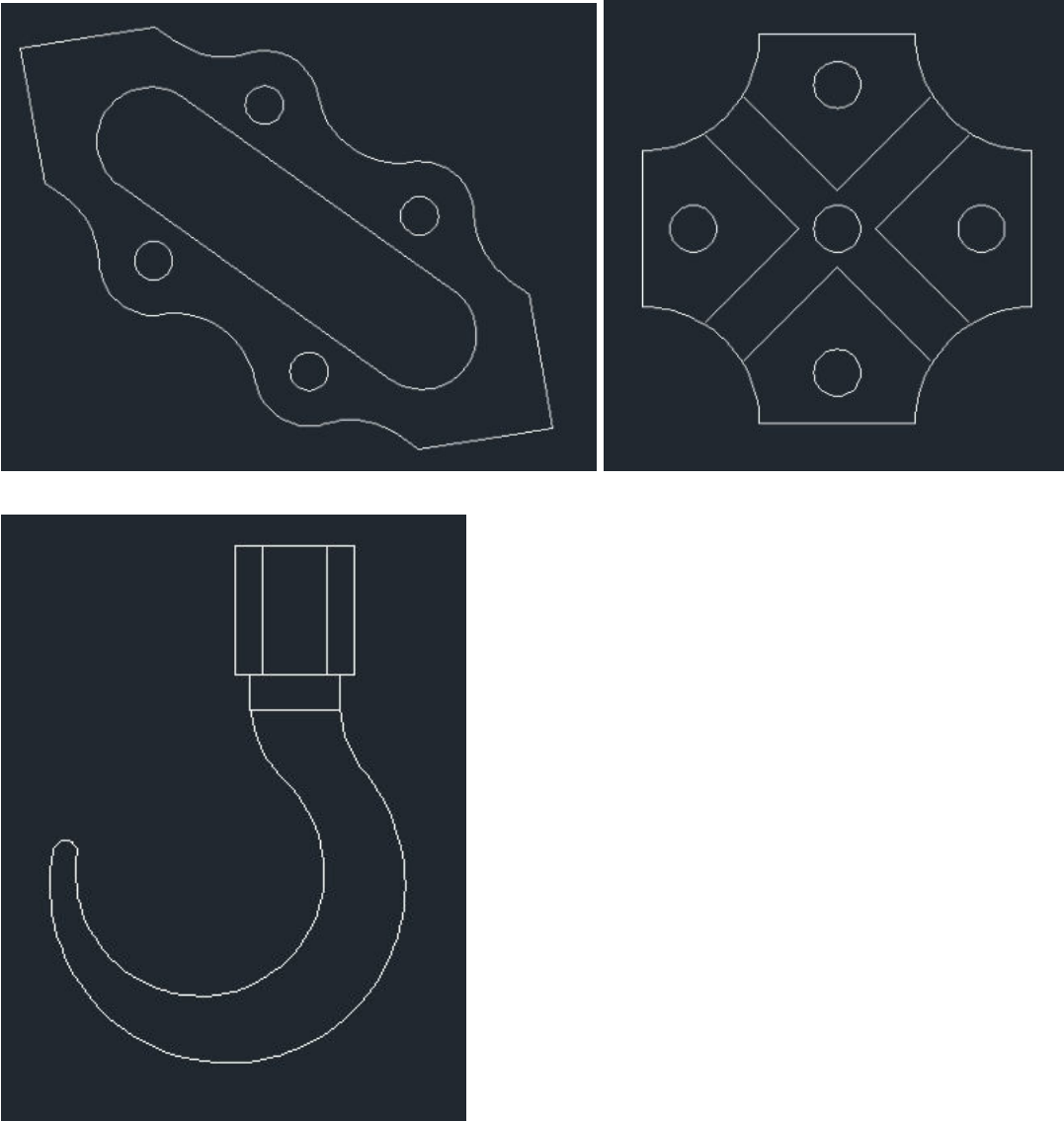

9. DIMENSION TOOLBAR

You can create several types of dimensions for a variety of object types in many orientations and alignments.

The basic types of dimensioning are linear, radial, angular, ordinate, and arc length. Use the DIM command to create dimensions automatically according to the object type that you want to dimension.

You can control the appearance of dimensions by setting up dimension styles, or by editing individual dimensions in special cas-

es. Dimension styles allow you to specify your conventions quickly and maintain industry or project dimensioning standards

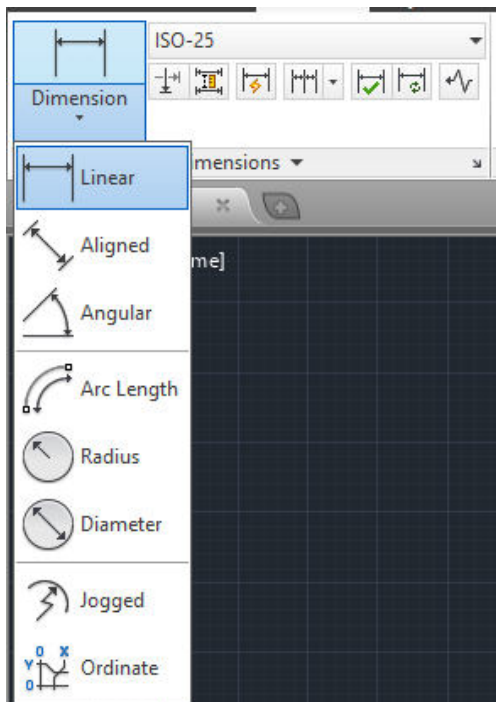

1. Linear Dimensions - Linear dimensions can be horizontal, vertical, or aligned. You can create an aligned, horizontal, or vertical dimension with the DIM command depending on how you move the cursor when placing the text.



2. Radial dimensions- A radial dimension measures the radius or diameter of arcs and circles with an optional centreline or centre mark.

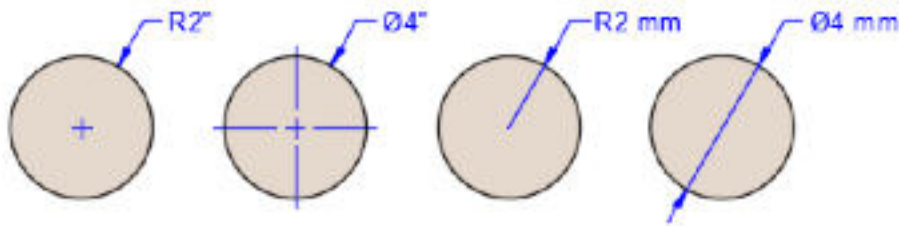

3. Angular dimensions- Angular dimensions measure the angle between two selected geometric objects or three points.

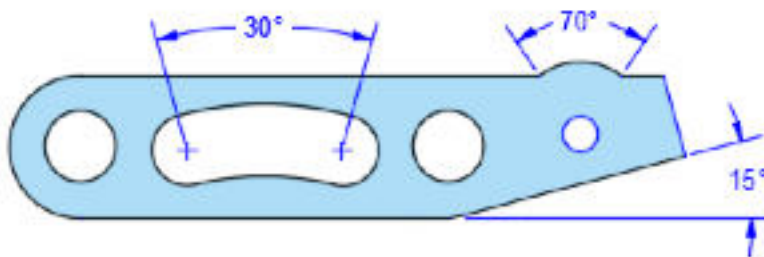

4. Ordinate Dimensions - Ordinate dimensions measure the perpendicular distances from an origin point called the datum, such as a hole in a part. These dimensions prevent escalating errors by maintaining accurate offsets of the features from the datum.

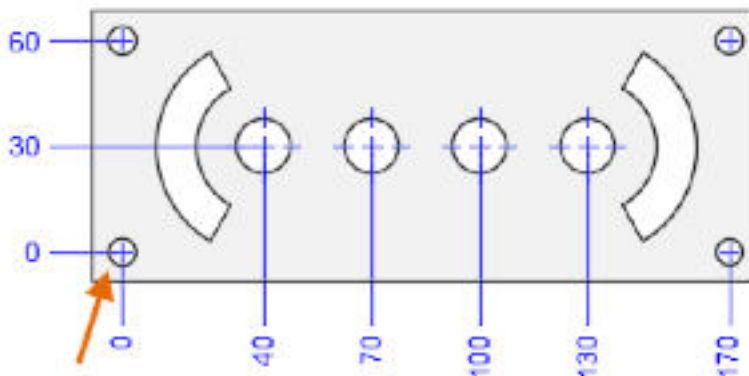

5. Arc Length Dimensions - Arc length dimensions measure the distance along an arc or polyline arc segment. Typical uses of arc length dimensions include measuring the travel distance around a

cam or indicating the length of a cable. Arc length dimensions measure the distance along an

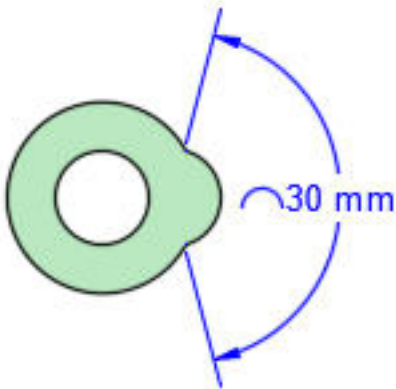

6. Baseline and Continued Dimensions - Continued dimensions also called chained dimensions, are multiple dimensions placed end-to-end.

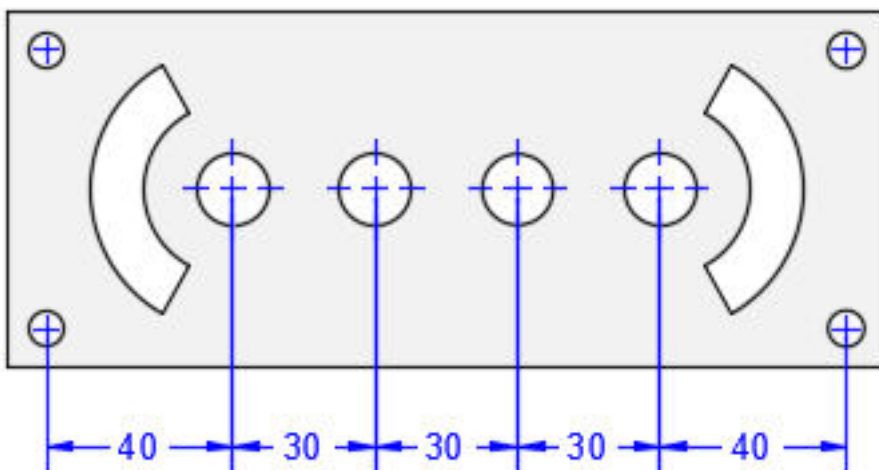

Baseline dimensions are multiple dimensions with offset dimension lines measured from the same location

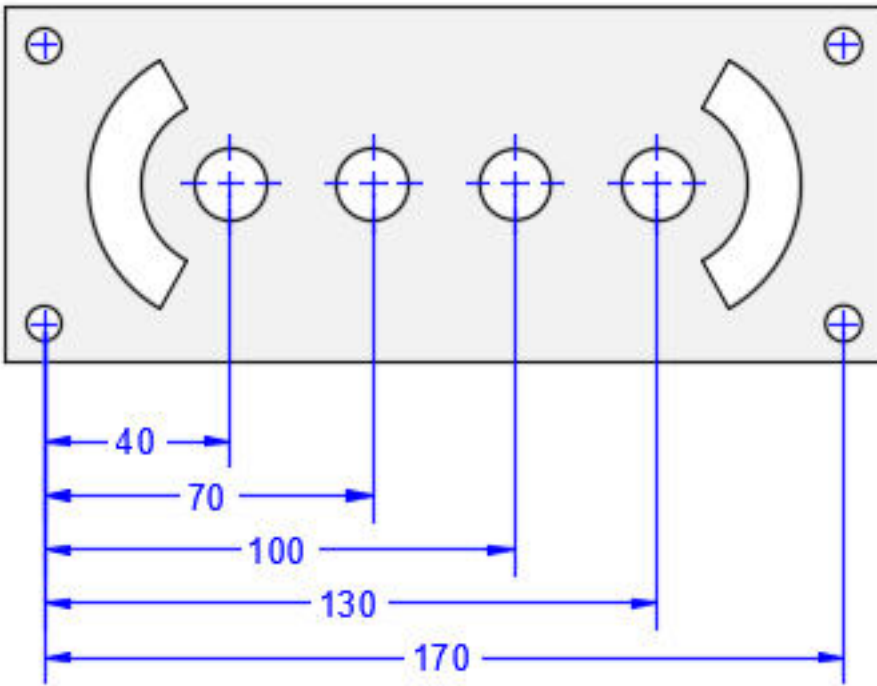

Some Drawings with Dimensions:

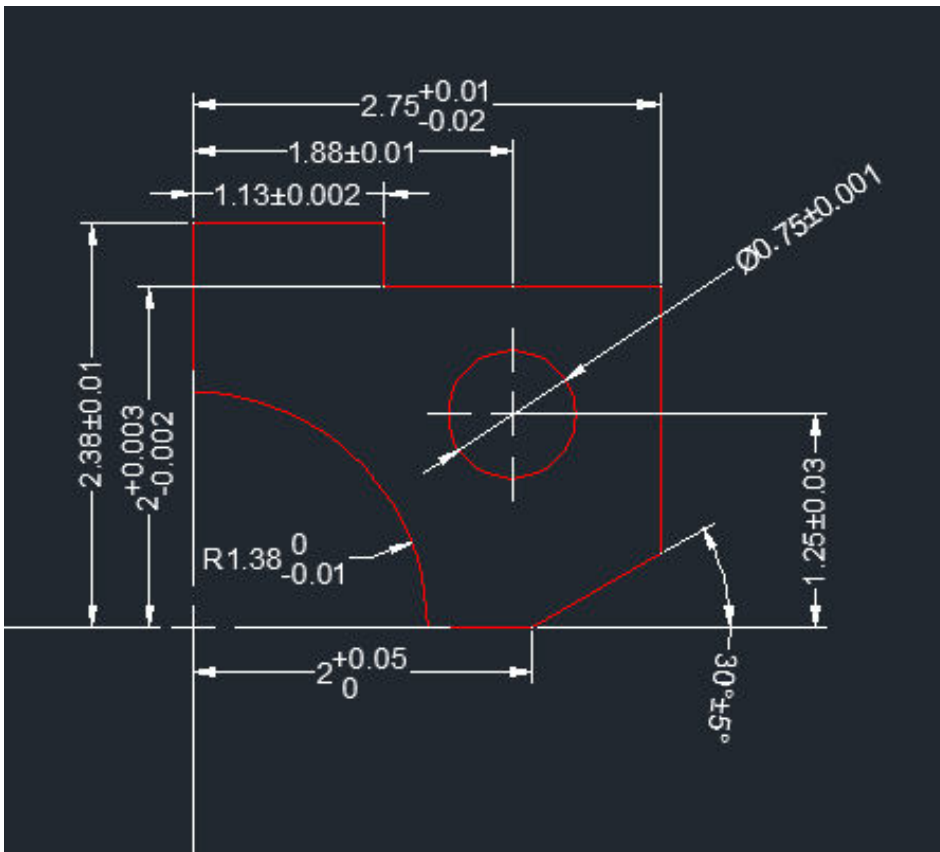

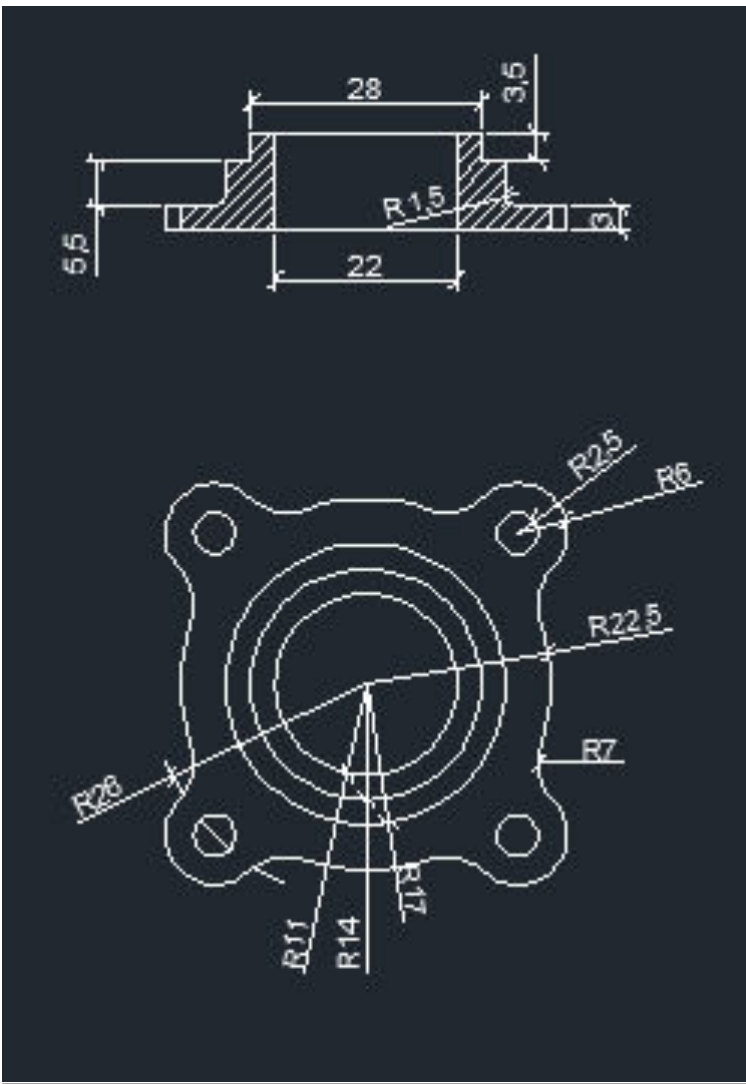

10. TEXT COMMAND

1. **A** Multiline Text - For longer notes and labels with internal formatting, use multiline text
2. **A** Single-line Text - For short, simple notes and labels, use single-line text.

Some Drawings including Text

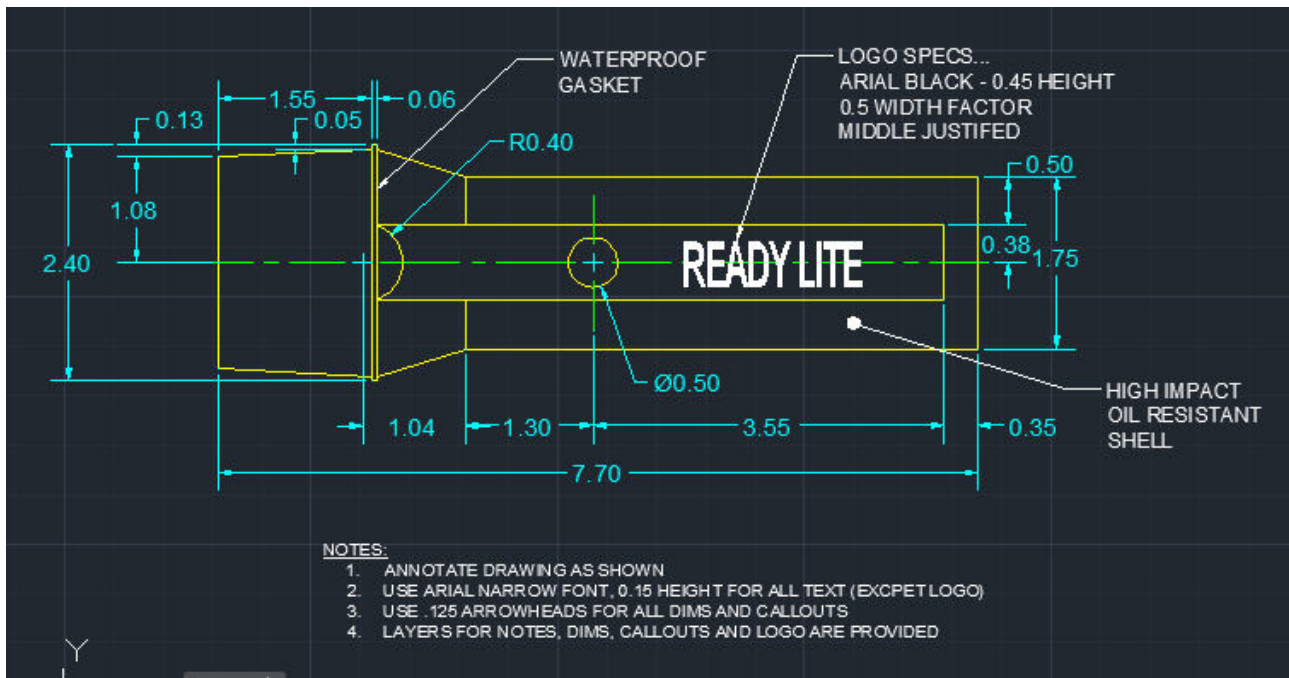

11. TABLE

A table is a compound object that contains data in rows and columns. It can be created from an empty table or a table style. A table can also be linked to data in a Microsoft Excel spreadsheet.

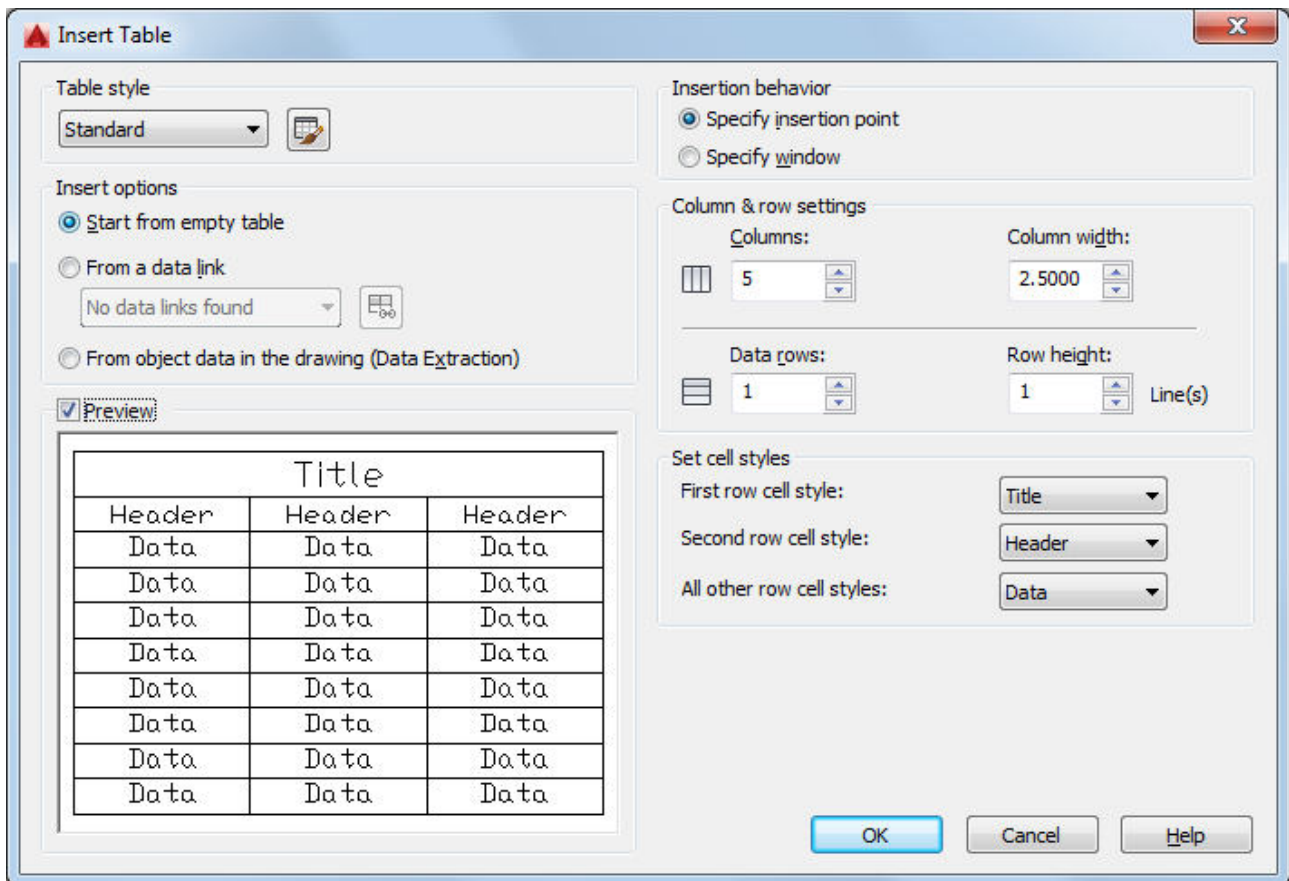

Some Drawings of Tables

	A	B	C
1	Database of Student		
2	S. No.	Name	Fees
3	1	Pawan	1000
4	2	Sachin	1500
5	3	Suraj	1500
6	4	Arun	2000
7	Total		6000
8			
9			

12. LAYER

Layers are the primary method for organizing the objects in a drawing by function or purpose. Layers can reduce the visual complexity of a drawing and improve display performance by hiding information that you don't need to see at the moment. You gain this level of control by organizing the objects in your drawing on layers that are associated with a specific function or a purpose. It might be helpful to think of layers as clear plastic sheets:

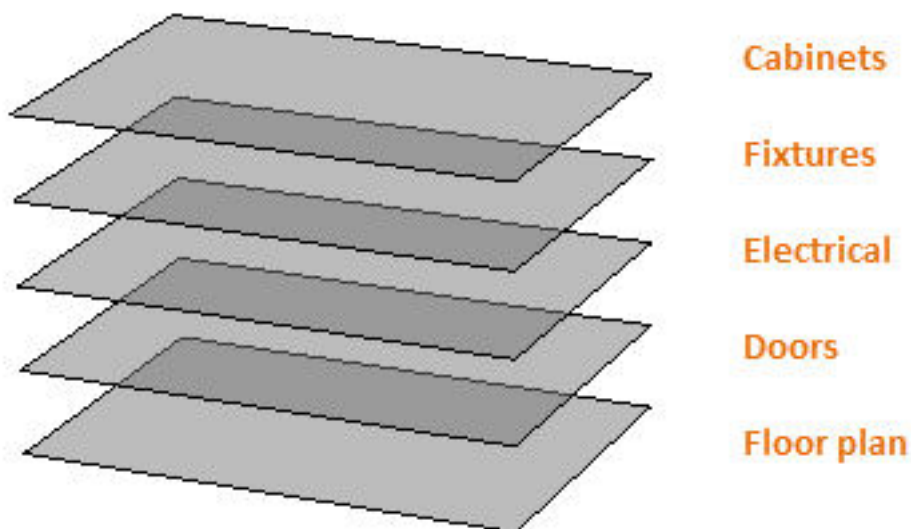

With layers, you can

- €Associate objects by their function or location
- €Display or hide all related objects in a single operation
- Enforce line type, colour, and other property standards for each layer

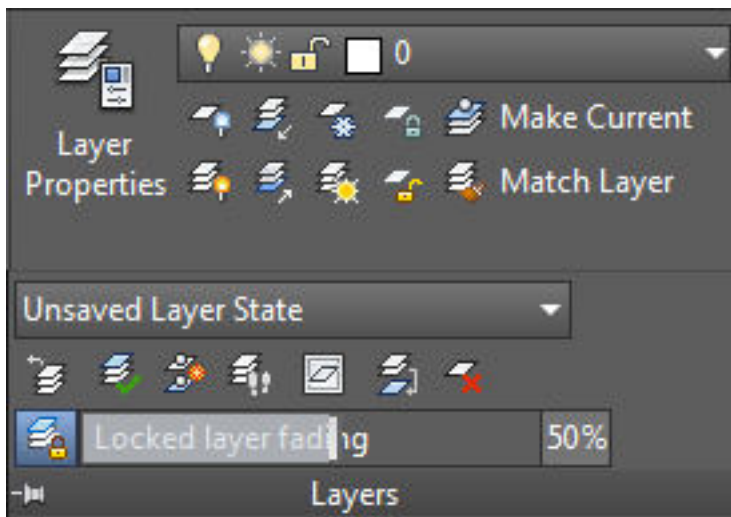

13. ISOMETRIC DRAWINGS

A 2D isometric drawing is a flat representation of a 3D isometric projection. This method of drawing provides a fast way to create an isometric view of a simple design. Distances measured along an isometric axis are correct to scale, but because you are drawing in 2D, you cannot expect to extract other 3D distances and areas, display objects from different viewpoints, or remove hidden lines automatically.

By using the **ISO DRAFT** command several system variables and settings are automatically changed to values that facilitate angles. The standard isometric planes, called **iso planes**, are as follows:

- **€Right**. Aligns snap and grid along 30- and 90-degree axes.
- **Left**. Aligns snap and grid along 90- and 150-degree axes
- **Top**. Aligns snap and grid along 30- and 150-degree axes.

Choosing one of the three iso planes automatically causes the crosshairs cursor, and precision drawing and tracking tools to be aligned along the corresponding isometric axes. Therefore, you

can draw the top plane, switch to the left plane to draw a side, and switch to the right plane to complete the drawing.

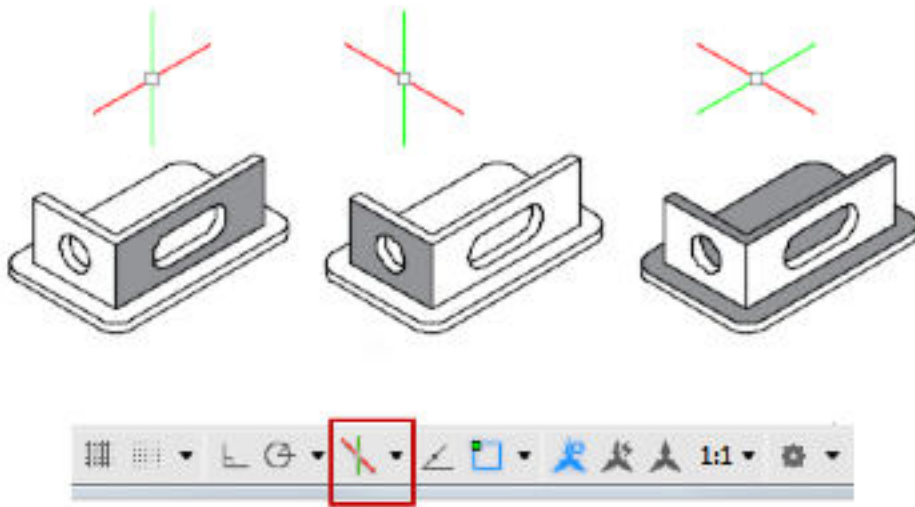

You can use the Isometric Drafting tool on the status bar to select the desired isoplane. Alternatively, you can press F5 or Ctrl+E to cycles through the isoplanes.

Some Isometric Drawing

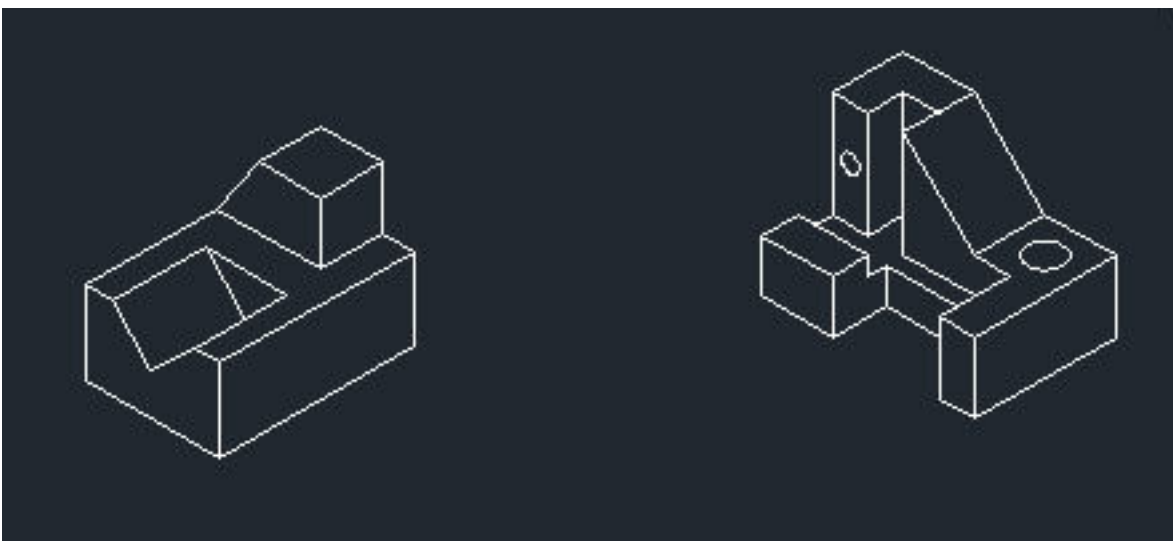

14. 3D MODELING

3D solid primitives are standard shapes which are provided among the ribbon options on the 3D modeling workspace. They include box, wedge, cone, cylinder, sphere, pyramid and torus. The principles of drawing them are similar.

- 
Box: Box command on the toolbar modeling is used to draw 3D models such as cubes and block. creates a box with sides of equal length.

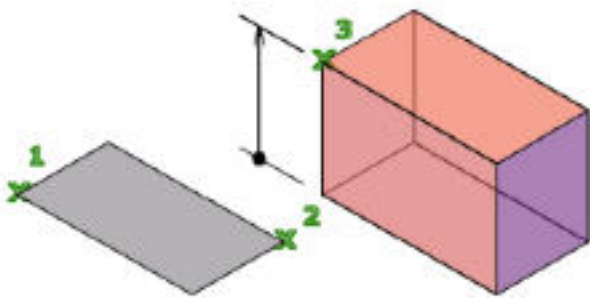

- 
Cylinder: The cylinder was created using a centre point (1), a point on the radius (2), and a point for the height (3). The base of the cylinder is always on a plane parallel with the work plane.

Cylinder: The cylinder was created using a center point (1), a point on the

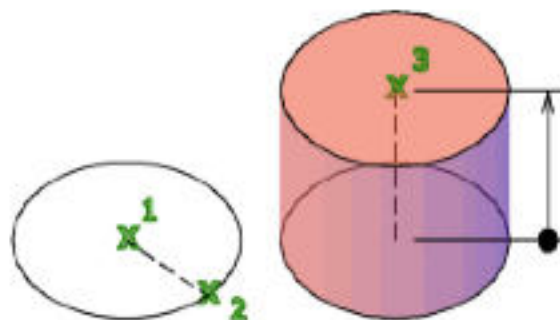

-  **Sphere:** Specifies the center point of the sphere. When you specify the center point, the sphere is positioned so that its central axis is parallel to the Z axis of the current user coordinate system (UCS). Defines the radius or diameter of the sphere.

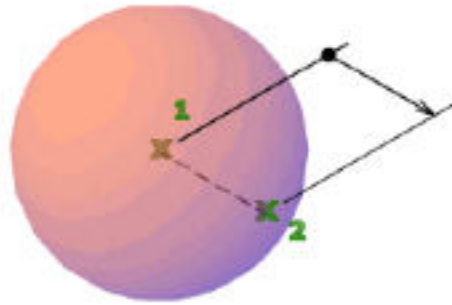

- **Wedge:** The direction of the taper is always in the positive X-axis direction of the UCS.

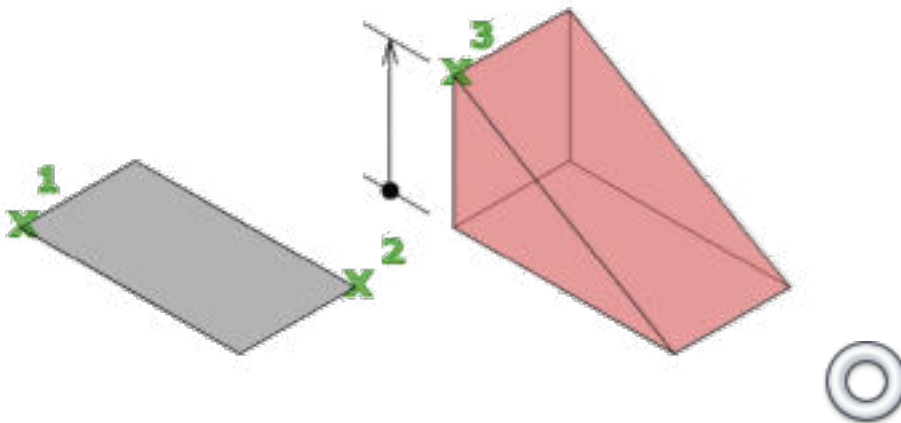

- **Torus:** Specifies the center point of the torus. When you specify the center point, the torus is positioned so that its central axis is parallel to the Z axis of the current user coordinate system (UCS). Defines the radius of the torus and then define the radius of the tube.

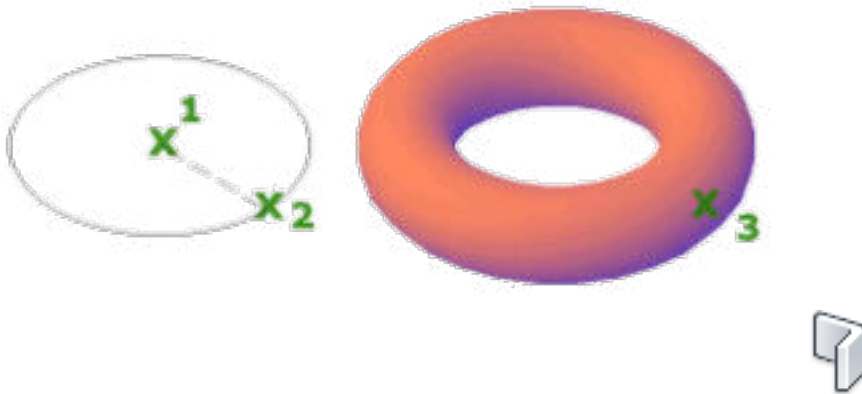

- **Polysolid:** You can create a 3D solid with polysolid just as you would a polyline. You can also convert existing 2D objects such as lines, 2D polylines, arcs, and circles to 3D solids with a default height, width, and justification.

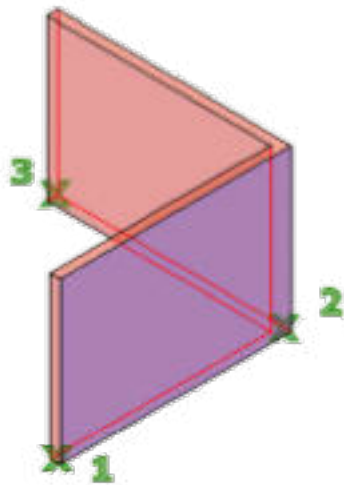

-  Extrude:object, in a specified direction, or along a selected path. You can also specify a taper angle. Objects can be extruded orthogonally from the plane of the source

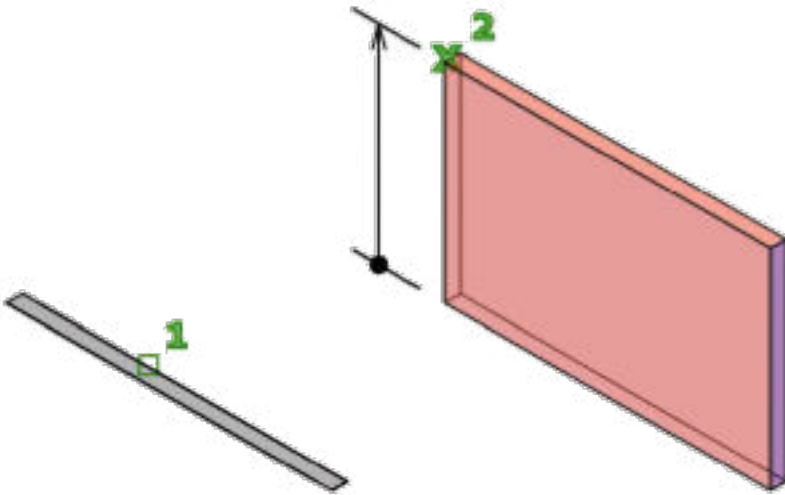

- 
Loft: Creates 3D solid or surface in the space between several cross sections. The cross sections define the shape of the resulting solid or surface. You must specify at least two cross sections.

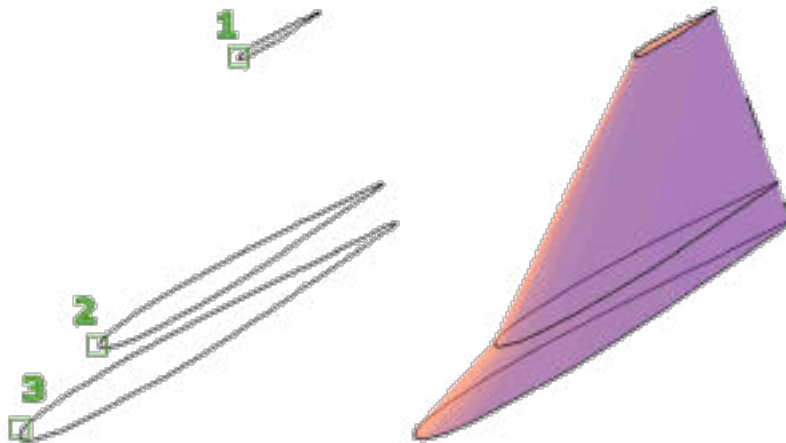

- 
Sweep: Sub object along an open or closed path. Creates a 3D solid or 3D surface by sweeping a 2D object or

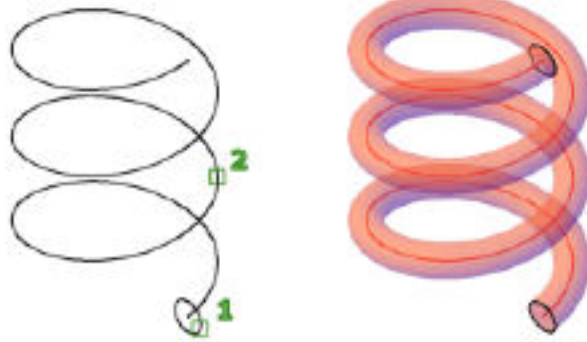

- 
Revolve: Creates a 3D solid or surface by sweeping an object around an axis. You cannot revolve objects contained within a block or objects that will self-intersect. REVOLVE ignores the width of a polyline and revolves from the center of the path of

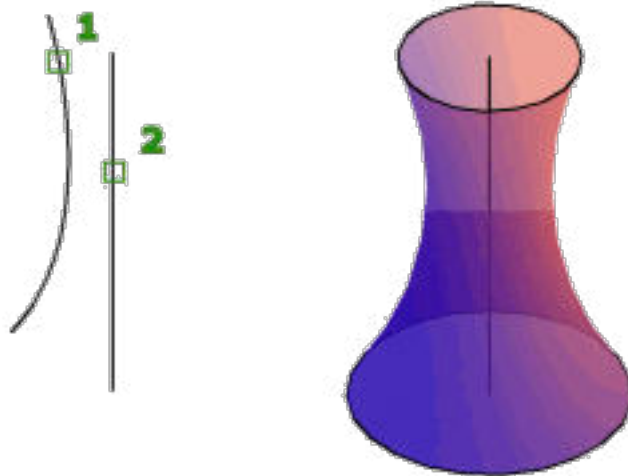

the polyline.

BOOLEAN OPERATIONS:

- 
Union: Combines two or more 3D solids, surfaces, or 2D regions into a single, composite 3D solid, surface, or region. Select two or more objects of the same type to combine.

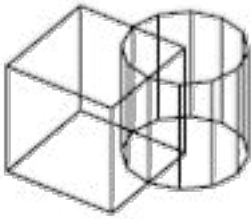

solids before UNION

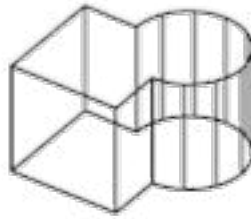

solids after UNION

- 
Subtract: Creates as a new object by subtracting one overlapping region or 3D solid from another. Objects in the second selection set are subtracted from objects in the first selection set. A single new 3D solid or surface is created.

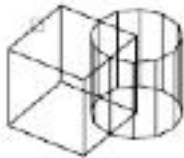
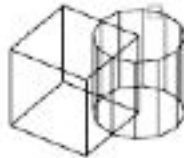
solid to be subtracted
from

solid to subtract



solid after SUBTRACT

- Intersect:** With INTERSECT, you can create a 3D solid from the common volume of two or more existing 3D solids, surfaces, or regions. If you select a mesh, you can convert it to a solid or surface before completing the operation. You can extrude 2D profiles and then intersect them to create a complex model efficiently. Select intersect command. Select the two object which intersect and then tap enter.

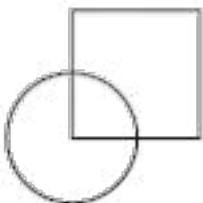
regions before
INTERSECT

region after INTERSECT

Some 3D Drawings

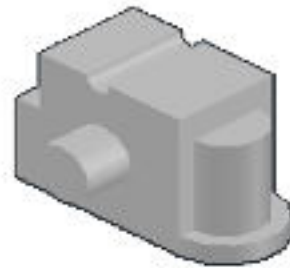
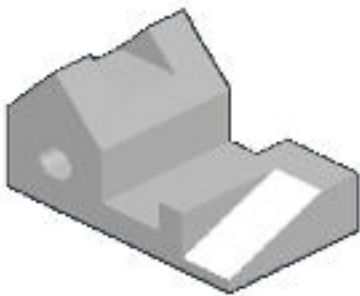
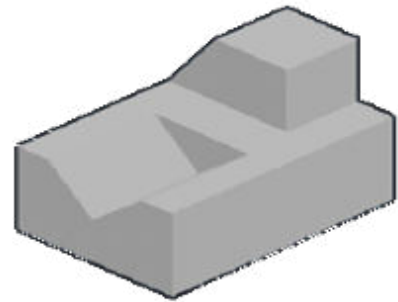
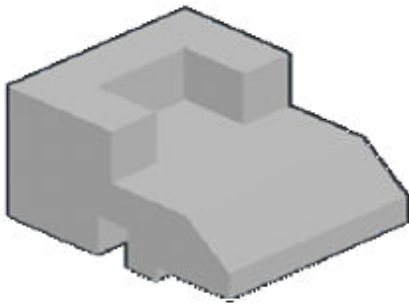

15. PRINTING AND PLOTTING

Output a drawing layout to a printer, a plotter, or a file. Save and restore the printer settings for each layout. Originally, people printed text from printers and plotted drawings from plotters. Now, you can do both with either



Some PDF Format of Drawing

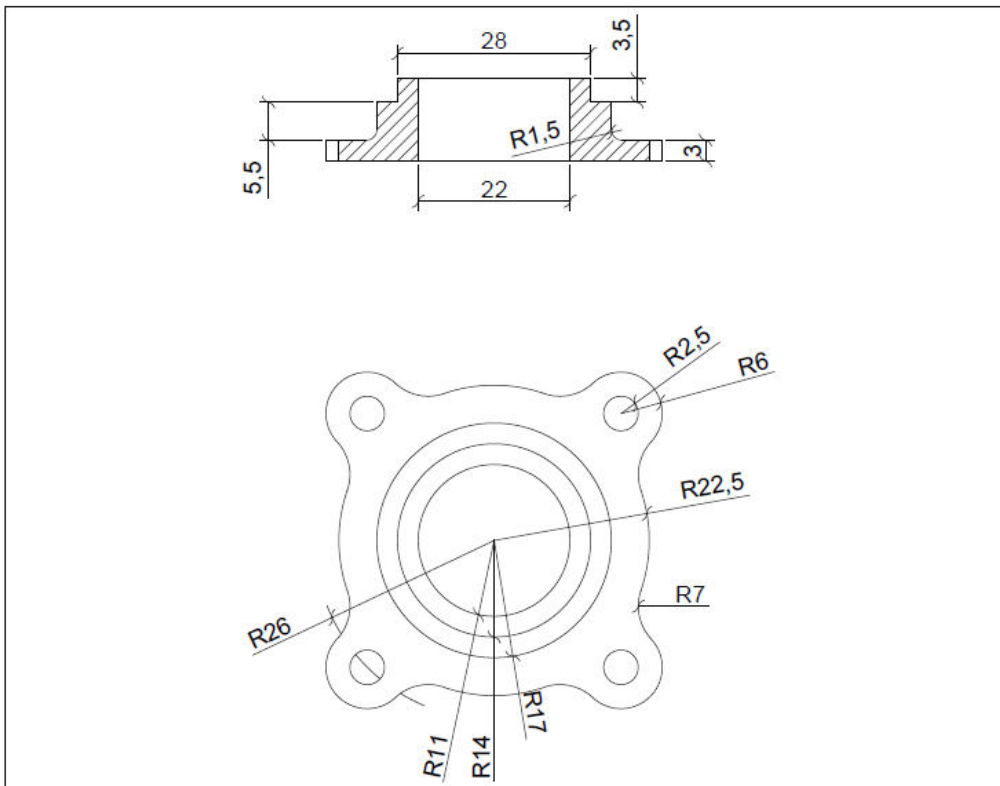
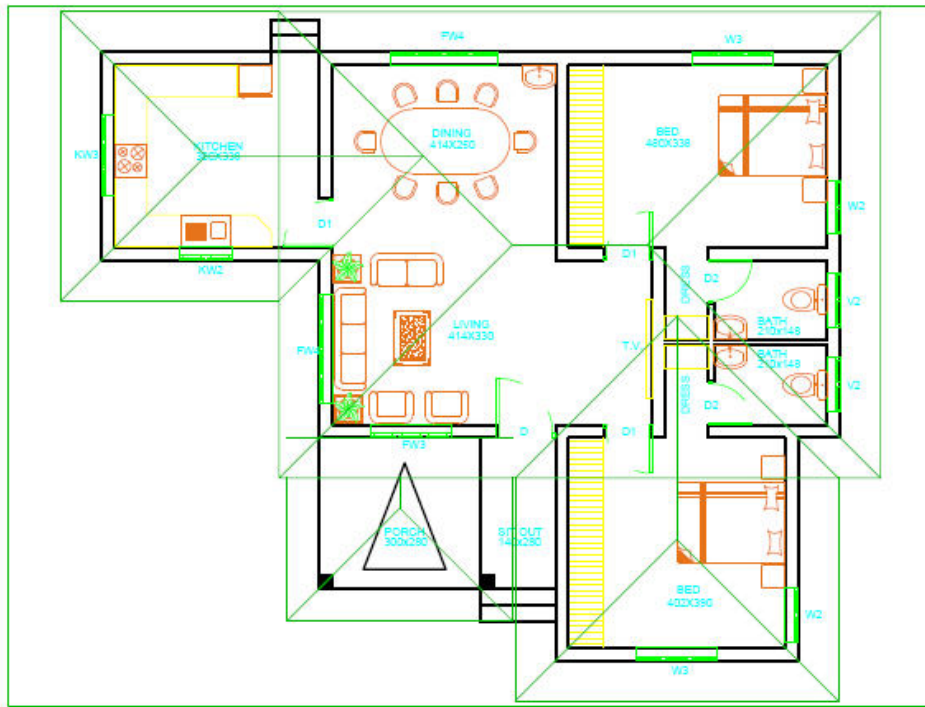

CONCLUSION

This report covered the preview of our learning path and study materials. The use of AutoCAD has many advantages. It can help to reduce the time it takes to produce the drawing needed in the work environment. AutoCAD software is the most amazing range of mechanical computer aided design tool. It is now considered to be the best according to industry standards that can be obtained for a wide array of designing, Mechanical Engineering Services and other industrial purposes.

The use of AutoCAD may also be relied on heavily in order to create efficiencies within the industries. We explored different materials ranging from text, tutorials and Youtube videos so as get to grips with the finer details of mastering AutoCAD. We were guided by the fact that there is more to learning AutoCAD than drawing simple figures and lines. It has very vast application in the field of manufacturing, architecture, electrical, and many more. The company Autodesk provides wide range of application and software which reduces the effort to create complex drawing and easy to maintain. With the help of AutoCAD, we can create design very quickly. It improves the quality of the drawing which we can't get by hand drafting. With the help of this software, drawing can be easily modified whenever wanted which reduces the human effort. We can easily transfer files from one place to another in no time which reduces the time.

This software is utilized to provide some useful and practical designing software that will allow users to visualize as well as create prototypes of a product in reality and quick time. AutoCAD software allows developers to give form to their out of the box ideas.

WEBSITES:

- <https://www.autodesk.com/company>
- <https://en.wikipedia.org/wiki/Internshala>
- <https://www.google.com/>